







Ergonomic

Simple automation



				
Ergonomic 290.258 DGANC	0°	258	325 x 180	258
Right	45°	210	215 x 100	195
Left	45°	180	235 x 80	195
Right	60°	125	135 x 100	125
Working mode	automatic			
Smallest sawing diameter	ø 5 mm			
Length of cut-off piece	280 mm (0 ° cutting angle)			
Saw band speed	20 - 120 m/min			
Saw band dimensions	2 910 x 27 x 0,9 mm			
Drive	1,5 kW, 3 x 400 V, 50 Hz			
Machine dimensions	Length - 2 900 mm / Width - 1 850 mm Height - 1 650 mm / Weight - 1 500 kg			

For more information about the machine and the possibility of extending it, please contact our sales department.

Ergonomic automatic

Universal automatic bandsaw with a robust cast-iron arm and 27 mm high saw band. Material clamping and arm downfeed are controlled hydraulically. A fully automatic band saw for double-sided mitre cuts with automatic arm positioning. Material downfeed and clamping and arm downfeed are controlled hydraulically. The maximum length of an individual feed is 1,500 mm. The whole work cycle is completed after the length and number of pieces and angles on each side of a piece have been programmed. The control unit is equipped with a large display. The programming is performed in simple steps, and thanks to a large graphic display of individual sections it is easy to control for the user. Up to 60 programs may be saved in the unit. After switching the machine to the manual mode, all functions of the machine may be controlled separately.

The robust arm is made from grey cast-iron, which means better vibration absorption during cutting than with a welded arm. The outstanding cutting power of the machine results from the following features: a hardmetal band precision guide, an arm joint laid in preloaded conical bearings, a 27 mm high saw band and lastly, a synchronous running brush for chips disposal. The vices are laid solid on preloaded linear guiding. The movable vice opens to both sides, which eliminates collisions with uneven materials. A continuous roller track ensures simple and safe feeding of short materials.

The angles are set electromechanically from -45° to $+60^{\circ}$ within approx. 3 sec.

Flexible solution

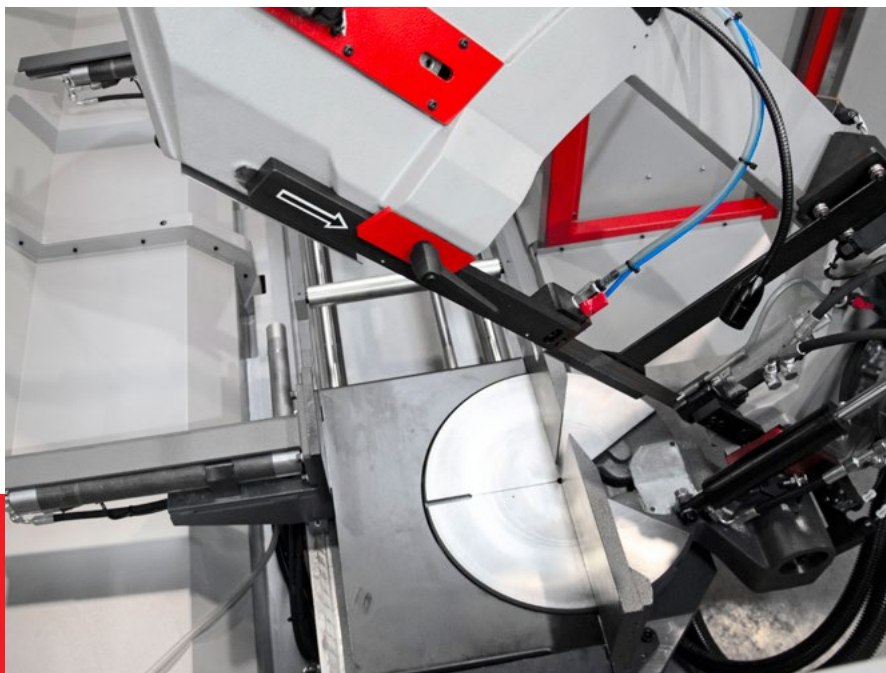

The automatic cutting pressure regulation automatically adapts the cutting feed and pressure to the material. The result is higher cutting output and longer service life.

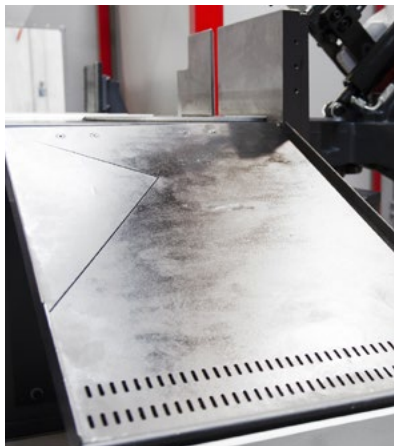

The entire material feeding area is designed as a transit roll-way with embedded rollers.



Remote diagnostic and maintenance

Maintenance status and error reports are sent through an internet connection, reducing operational downtimes.

Sample assembly

Ergonomic 290.258 DGANC
SLE material feeding system

SLE system / Material handling system

Simple and reliable inclined material loader device, designed primarily for Ergonomic DGANC series saws. It is a solution for uncomplicated automation in small and medium cutting operations. Thanks to the Plug-N-Play system, the device is ready to perform its function almost immediately.



Video on Youtube.com

For more information about the machine and the possibility of extending it, please contact our sales department.



BOMAR, spol. s r.o.

Těžební 1236/1
627 00, Brno
Česká Republika

Tel. + 420 533 426 100
info@bomar.cz

www.bomar.cz