



for impressive  
performances

# HACO VULCAN





The VULCAN's gantry can be equipped with one or more **Oxy-fuel cutting torches**.

Each oxy-fuel torch carrier has an automatic flame ignition for the torch, as well as an integrated capacitive sensor "Hypertherm OHC" that controls the Z-axis movement (by brushless AC Servo motor) for correct setting of the cutting height

Complete gas distribution with separated heating and cutting chambers for oxygen distribution, two-stage control of the pressure of flammable gas, of heating and cutting oxygen; gradual recessing of material, controlled feeding start-up and pressure engagement.

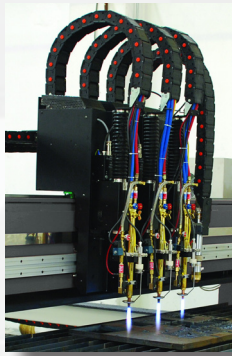

The integrated **PTHC torch lifter** unit controls the cutting height by means of a brushless servo motor

During the cutting process, the PTHC unit measures the Arc Voltage and adjust the Z-axis to maintain a constant cutting height, This results in optimum cutting parts.

Optional Hypertherm Arc Glide torch lifter is available

Optional magnetic breakaway feature is offered to reduce or eliminate damage to the torch due to accidental collisions.

#### **Machine table**

The VULCAN has an overdimensioned free standing cutting table which is constructed of separate chambers. The chambers are opened and closed separately, pneumatically controlled and zone programmable via the CNC in relation to the position of the gantry, what assures an efficient fume extraction.

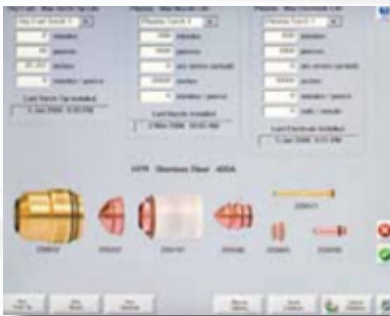

**Phoenix software** is the core operational interface and is common across the entire Hypertherm family of CNC systems. The software is designed specifically for the cutting market and is available in fourteen languages for easy operation.

#### **Key benefits include:**

- Integrated communications to plasma and torch height control systems for automated end expert control of the cutting process
- Built-in cut charts for automatically setting process parameters for mild steel, stainless and aluminum to enable consistently optimized cutting performance
- Wizards and diagnostics support tools that enable easy setup, use and rapid troubleshooting
- Built-in help and cutting optimization tips for improving table performance and process outcomes at the touch of a button



The **(Micro)EDGE Pro** CNC brings Hypertherm's latest hardware and Phoenix® software technology to a product that is customizable for a wide variety of applications. Designed for reliability and ease of use, the (Micro)EDGE Pro improves cut quality, productivity and profitability by delivering Hypertherm's cutting process expertise directly to your factory. It is as if you have your best operator on every shift.

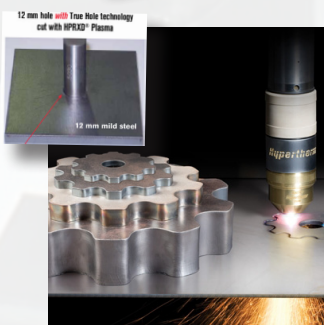

#### **Latest technologies such as True Hole (Tm) are complete integrated in Ecocut**

A conventional or a high-definition plasma cutting system can be offered, all depending on the application. Plasma Cutting Technology is known for its high productivity and low cost, and can be used for a wide range of thicknesses. The latest types of plasma with High-Definition Technology produce an excellent perpendicularity of cut, high speeds and clean cutting results.

#### **True Hole (Tm) Technology**

Hypertherm's patent-pending True Hole cutting technology for mild steel produces significantly better hole quality than what has been previously possible using plasma. This is delivered automatically without operator intervention, to produce unmatched hole quality that surpasses the competition.

## HYPERTHERM PLASMA SOURCES

### HYSPEED PLASMA SYSTEM HSD 130

*Easy, reliable, and incredibly productive*

**HySpeed Plasma HSD 130** is an easy-to-use oxygen plasma system that is more productive and more cost-effective than other metal cutting solutions such as oxyfuel, air plasma, and non-LongLife oxygen plasma systems.

With our patented LongLife technology and 100% duty cycle, HySpeed Plasma is in a class of its own - between our Powermax® air plasma line and our state-of-the-art HyPerformance® Plasma family of precision products.



<b>Virtually dress-free cutting capacity - mild steel</b>	<b>16 mm (5/8'')</b>
<b>Production pierce capacity - mild steel</b>	<b>25 mm (1'')</b>
<b>Maximum cutting capacity (edge start) - mild steel</b>	<b>38 mm (1 1/2'')</b>

### Hyperformance Plasma systems HPR XD

**HyPerformance Plasma** cuts, bevels and marks a variety of metals, from thin to thick, making it the system that can do it all.

HyPerformance Plasma cuts carbon steel, stainless steel, aluminum and other metals with HyDefinition precision. Full range of cutting thicknesses from 0,5 mm material to production piercing of 50 mm with a maximum cutting thickness up to 80 mm.

Components and capabilities have been specifically designed for use in X-Y, bevel and robotic cutting applications. Modular power supply and console design allows for easy upgrades to increase your capabilities.

#### Gas console options (only for XD)

##### Manual gas console

- Provides an intuitive and easy to use operator interface for the system.
- Operator manually select gas types and set gas flows.
- Automatically adjust for variations in incoming gas pressure to produce consistent cutting performance.



##### Auto gas console

- Controls all of the plasma system settings from the CNC. When coupled with an intuitive CNC interface it reduces the time it takes to train new operators and set up new jobs.
- Automatically changes processes on the fly to enable rapid switching between cutting and marking
- Automatically adjusts for variations in incoming gas pressure to produce the most consistent cutting performance.
- The auto gas console is required to enable True Hole technology.



#### System comparisons

##### Cutting speed

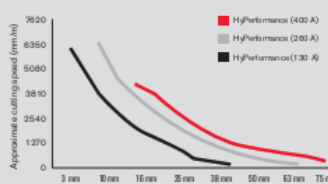

##### Consumable life

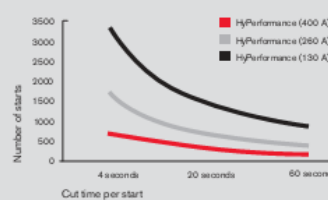

### Hyperformance Plasma product line

HyPerformance Plasma customers can choose the systems and combination of options that best suit their requirements today. Modules are designed to work interchangeably providing the flexibility of an easy upgrade path, allowing you to add new capabilities should your needs change in the future.

#### HPR130XD

(30 - 130 amps)

##### Mild steel cut capacity

Dress free: 16 mm  
Production (pierce): 32 mm  
Severance (edge starts): 38 mm

##### Stainless steel cut capacity

Production (pierce): 20 mm  
Severance (edge starts): 25 mm

##### Aluminium cut capacity

Production (pierce): 20 mm  
Severance (edge starts): 25 mm



#### HPR260XD

(30 - 260 amps)

##### Mild steel cut capacity

Dress free: 32 mm  
Production (pierce): 38 mm  
Severance (edge starts): 64 mm

##### Stainless steel cut capacity

Production (pierce): 32 mm  
Severance (edge starts): 50 mm

##### Aluminium cut capacity

Production (pierce): 25 mm  
Severance (edge starts): 50 mm



#### HPR400XD

(30 - 400 amps)

##### Mild steel cut capacity

Dress free: 38 mm  
Production (pierce): 50 mm  
Severance (edge starts): 80 mm

##### Stainless steel cut capacity

Production (pierce): 45 mm  
Severance (edge starts): 80 mm

##### Aluminium cut capacity

Production (pierce): 38 mm  
Severance (edge starts): 80 mm



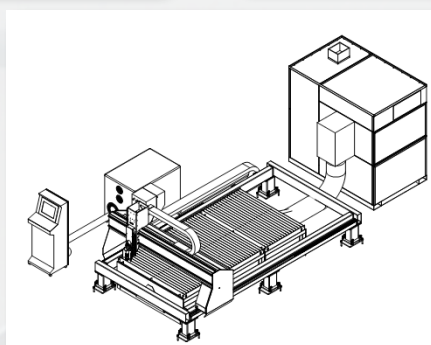
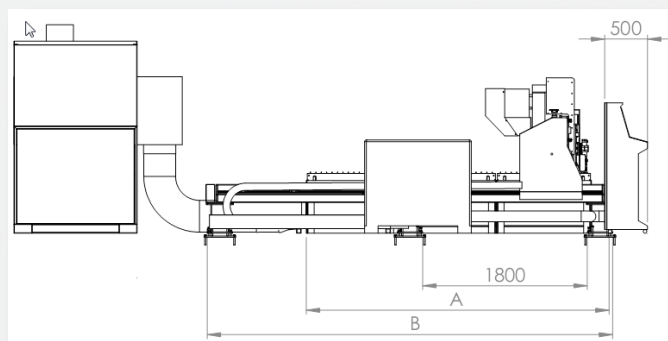
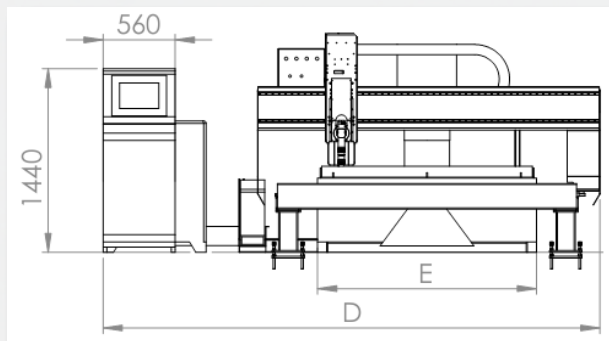

EcoCut				
Size (in meter)	E Table Width	A Table Length	D Total Width (incl. CNC)	B Rail Length
EC-2040 2 x 4	2.200	4.345	4.500	5.480
EC-2060 2 x 6	2.200	6.345	4.500	7.480
EC-2080 2 x 8	2.200	8.345	4.500	9.480
EC-20120 2 x 12	2.200	12.345	4.500	13.480
EC-3015 3 x 1,5	3.200	1.845	5.500	2.980
EC-3060 3 x 6	3.200	6.345	5.500	7.480
EC-3080 3 x 8	3.200	8.345	5.500	9.480
EC-30120 3 x 12	3.200	12.345	5.500	13.480
EC-30150 3 x 15	3.200	15.345	5.500	16.480
EC-30180 3 x 18	3.200	18.345	5.500	19.480
EC-30240 3 x 24	3.200	24.345	5.500	25.480
EC-4060 4 x 6	4.200	6.345	6.500	7.480
EC-4080 4 x 8	4.200	8.345	6.500	9.480
EC-40120 4 x 12	4.200	12.345	6.500	13.480
EC-40150 4 x 15	4.200	15.345	6.500	16.480
EC-40180 4 x 18	4.200	18.345	6.500	19.480
EC-40240 4 x 24	4.200	24.345	6.500	25.480
EC-60120 6 x 12	6.200	12.345	8.500	13.480
EC-60150 6 x 15	6.200	15.345	8.500	16.480
EC-60180 6 x 18	6.200	18.345	8.500	19.480
EC-60240 6 x 24	6.200	24.345	8.500	25.480
EC-60270 6 x 27	6.200	27.345	8.500	28.480
EC-60320 6 x 32	6.200	32.345	8.500	33.480
EC-60360 6 x 36	6.200	36.345	8.500	37.480