

## PRESS BRAKES



Press Brakes  
SynchroMaster  
EuroMaster-S  
PressMaster

# HACO's Affordable Bending Solutions to the Highest Standards

## Always the right choice for your application

- SynchroMaster Series **4**
- EuroMaster-S Series **12**
- PressMaster Series **18**

## Equipment

- FastBEND-2D/3D MT Premium **24**
- New Standard Tooling System **26**
- Smart Tool Locator **27**
- Lasersafe Optical Safety Guards **28**
- Angle Measuring System Alfa-F **30**
- Angle Measuring System IRIS Plus **31**
- Sheet Following Systems **32**
- SyncView **34**

HACO's pressbrake series are the result of a decades long tradition in designing and manufacturing affordable **state-of-the art bending machines** for a wide variety of customers and applications.

HACO continues its policy of single source responsibility. Our in house developed **CNC controls** and **software solutions** have been recognized as being among the most user-friendly in the market. The new generation **Multi Touch** controls sets a new standard for an intuitive and user-friendly operator interface, introducing innovations such as **Smart Draft, Step Previewer** and **Combined Icons**.

HACO's attention for **design** and **manufacturing quality** has resulted in a worldwide reputation of long lasting production machines offering **excellent reliability** and **precision**.

**FOLLOW THE HACO GROUP:**  
[WWW.HACO.COM](http://WWW.HACO.COM)



TheHACOGroup



@haco\_com



The HACO Group



hacogroup

# Our Press Brakes Series



## SynchroMaster (SRM)

Entry Level Machine

Entry level pressbrake with basic execution for operation with European Standard Tooling. Possibility to extend with straightforward options. Attractive price/quality ratio. Standard with user friendly 2D graphical control.



## EuroMaster-S (EMS)

Standard Multifunctional Allround machine

General level pressbrake with market oriented execution. Extensive choice of options, both basic and sophisticated. Innovative 2D Multi Touch graphical control. Excellent price-performance ratio. Integration of advanced safety equipment.



## PressMaster (PM)

Top Level High-Spec machine

Top level pressbrake with high-end specifications and execution. Increased Daylight Opening and Beam Stroke for increased bending freedom. Increased beam and backgauge speeds for high productivity. Innovative 3D Multi Touch graphical control. Possibility for extension with sophisticated options. Features accurate bending characteristics. Integration of advanced safety equipment.

# SynchroMaster Series

Your entry-level machine

## BEAM CONTROL

Beam parallelism and depth stop setting by means of bed referenced linear encoders for accurate beam position measurement, synchro module and proportional valve hydraulics

## INTUITIVE EASYBEND-2D CONTROL



## EASYBEND-2D T

Touch Screen control (optional)



# SynchroMaster Series

SRM

## CROWNING TABLE (OPTIONAL)

Compensates for ram and table deflection, ensuring consistent bending angles over the entire bending length.  
Manual operation and CNC controlled versions (V-axis)

## STANDARD BACKGAUGE X

Rigid backgauge for accurate sheet positioning

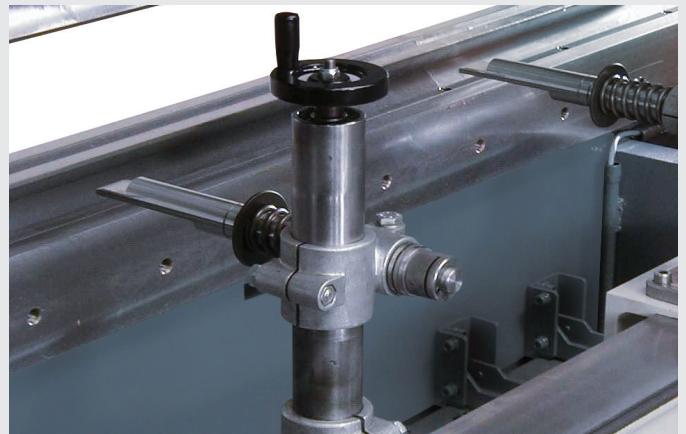

## STANDARD EUROPEAN

Quick Manual Upper clamping  
Manual bottom clamping



*Model 40250*

*Flush Floor frame  
design for all models*

# SynchroMaster Series

## Standard Execution

### INTUITIVE EASYBEND-2D GRAPHICAL CONTROL

Intuitive entry level control for 2D applications with graphical support during work piece design and production cycle.

Automatic bending sequence calculation, collision detection and program generation.  
User friendly interface enabling operation by low to medium skilled operators.

### SPECIFICATIONS:

- **10.4"** colour graphic LCD display
- WIN7 Embedded operating system
- Multiple drawing methods
- Graphic simulation of work pieces with **Multitasking Real Time solution Finding**
- **Automatic bending sequence calculation** with collision control
- Automatic program generation
- Expandable up to **7 axes**:
  - standard Y1 + Y2
  - standard X-axis
  - optional R-axis
  - optional X-R-Z/Z' and X-R-Z1-Z2 axes
  - optional crowning (= V-axis)
- Material library up to **30 different materials**
- Tool library with graphical visualisation for
- **30 upper** and **30 lower tools**
- **USB Support** (stick included) + Network board
- **Programmable Beam Speed** and **Speed Change-Over Point**
- **Top Death Centre (TDC)**, Back gauge Positioning with retraction



# SynchroMaster Series

## Standard Execution



### EUROPEAN STANDARD (ES) top tooling with Quick Manual Clamping arrangement

The European Standard Tooling System has proven its flexibility, affordability and precision during the last decades in an infinite number of sheet metal working shops. A wide choice of a vast number of top and bottom tools allows for a unpredictable number of applications in various materials and thicknesses.

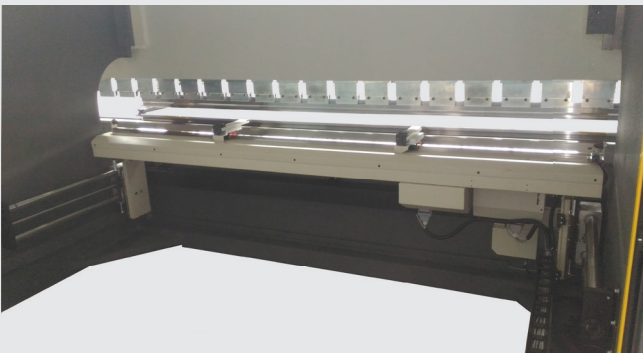

### X BACKGAUGE, expandable to X-R, X-R-Z/Z' and X-R-Z1-Z2

The SynchroMaster is standard equipped with a rigid and accurate X backgauge featuring average travelling speeds. Optional X-R (height programming), X-R-Z/Z' (symmetric finger programming) and X-R-Z1-Z2 (asymmetric finger programming) are available for increasing your range of applications.

*Picture: X-R backgauge*

- **EasyBEND-2D control**
- **X Backgauge for accurate sheet positioning**
  - Stroke X = 800mm, maximum speed = 400mm/s
  - Stroke R = 250mm, maximum speed = 100mm/s (Optional)
- **European Standard (ES) top clamping with Quick Manual Clamping Arrangement**
- **Intermediate clamping with height 150mm (all models ≤ 3200 kN),  
height 120mm HD version ( all models = 4000 kN)**

## Your Competitive Edge

**A. Excellent Value for Money**

**B. User Friendly EasyBEND-2D graphical control**

**C. Proven Profitability for Various Workload Conditions**

# SynchroMaster Series

## Technical Specifications

	Bending length	Capacity	Distance between housings	Gap	Daylight opening	Stroke	Table Height	Fast Approach Speed	Max. Bending Speed	Fast Return Speed	Motor Power	Length	Width	Height	Weight
	A		B	C	D	E	G					F	I	J	
MODEL	mm	kN	mm	mm	mm	mm	mm	mm/s	mm/s	mm/s	kW	mm	mm	mm	kg
20075	2100	750	1600	400	520	270	920	150	10	100	11	2500	1500	2900	5600
25075	2600	750	2100	400	520	270	920	150	10	100	11	3000	1500	2900	6800
30075	3100	750	2600	400	520	270	920	150	10	100	11	3500	1500	2900	7700
25100	2600	1000	2100	400	520	270	920	200	10	125	11	3000	1700	2930	7200
30100	3100	1000	2600	400	520	270	920	200	10	125	11	3500	1700	2930	7800
36100	3660	1000	3150	400	520	270	920	200	10	125	11	4060	1700	2930	10200
40100	4100	1000	3150	400	520	270	920	200	10	125	11	4500	1700	2930	10500
43100	4300	1000	3750	400	520	270	920	200	10	125	11	4700	1700	2930	11800
25150	2600	1500	2100	400	520	270	920	200	10	125	15	3000	1700	2930	7800
30150	3100	1500	2600	400	520	270	920	200	10	125	15	3500	1700	2930	9400
36150	3660	1500	3150	400	520	270	970	200	10	125	15	4060	1700	2930	11300
40150	4100	1500	3150	400	520	270	970	200	10	125	15	4500	1700	2930	11700
43150	4300	1500	3750	400	520	270	970	200	10	125	15	4700	1700	2930	13200
25200	2600	2000	2100	400	520	270	920	200	8	120	18.7	3000	2050	2920	10400
30200	3100	2000	2600	400	520	270	920	200	8	120	18.7	3500	2050	2920	11500
36200	3660	2000	3150	400	520	270	920	200	8	120	18.8	4060	2050	2920	12300
40200	4100	2000	3150	400	520	270	920	200	8	120	18.7	4500	2050	2920	13100
43200	4300	2000	3750	400	520	270	920	200	8	120	18.7	4700	2050	2920	16400
30250	3100	2500	2600	400	520	270	895	130	8	90	18.7	3500	2050	2920	13500
36250	3660	2500	3150	400	520	270	895	130	8	90	18.7	4060	2050	2920	15000
40250	4100	2500	3150	400	520	270	895	130	8	90	18.7	4500	2050	2920	15300
43250	4300	2500	3750	400	520	270	895	130	8	90	18.7	4700	2050	2920	16700
50250	5000	2500	4050	400	520	270	945	130	8	90	18.7	5400	2050	2920	24300
60250	6000	2500	5050	400	520	270	1090	130	8	90	18.7	6400	2050	2920	31000
30320	3100	3200	2600	400	620	420	895	100	8	95	22.5	3500	2025	3490	17500
36320	3660	3200	3150	400	620	420	895	100	8	95	22.5	4060	2025	3490	20000
40320	4100	3200	3150	400	620	420	895	100	8	95	22.5	4500	2025	3490	21500
43320	4300	3200	3750	400	620	420	895	100	8	95	22.5	4700	2025	3490	23500
50320	5000	3200	4050	400	620	420	940	100	8	95	22.5	5400	2025	3490	28000
60320	6000	3200	5050	400	620	420	1095	100	8	95	22.5	6400	2025	3490	33000
30400	3100	4000	2600	400	620	420	1045	90	7	60	37.5	4100	2270	3950	26500
36400	3660	4000	3150	400	620	420	1045	90	7	60	37.5	4660	2270	3950	29500
40400	4100	4000	3150	400	620	420	1045	90	7	60	37.5	5100	2270	3950	31500
43400	4300	4000	3150	400	620	420	1045	90	7	60	37.5	5300	2270	3950	32000

Specifications subject to modifications without price notice

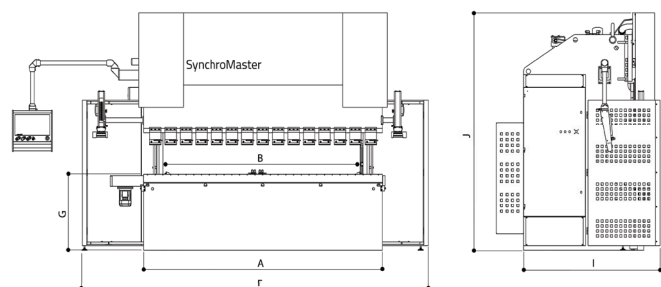
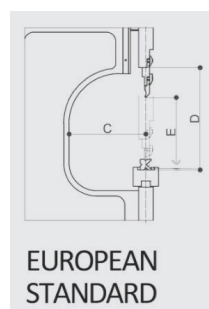



# SynchroMaster

## EasyBEND-2D T Control (Optional)

### EASYBEND-2D T CONTROL

- **18.5" multi colour graphic LCD display with Touch Screen Technology**
- WIN10 IoT operating system
- Multiple drawing methods
- Graphic simulation of work pieces with **Multitasking Real Time solution Finding**
- **Automatic bending sequence calculation** with collision control
- Automatic program generation
- **Unlimited number of programs**
- Expandable up to **7 axes**:
  - standard Y1 + Y2
  - standard X-axis
  - optional R-axis
  - optional X-R-Z/Z' and X-R-Z1-Z2 axes
  - optional crowning (= V-axis)
- Material library up to **30 different materials**
- Tool library with graphical visualisation for
- **30 upper and 30 lower tools**
- **Multi-language support**
- **USB Support** (stick included) + Network board
- **Remote diagnostics**
- **Programmable Beam Speed** and **Speed Change-Over Point**
- **Top Death Centre (TDC)**, Back gauge Positioning with retraction



# SynchroMaster

## Optional equipment

### X-R BACKGAUGE



### MANUAL CROWNING

Manual Anti-Deflection table for European Standard Bottom tooling

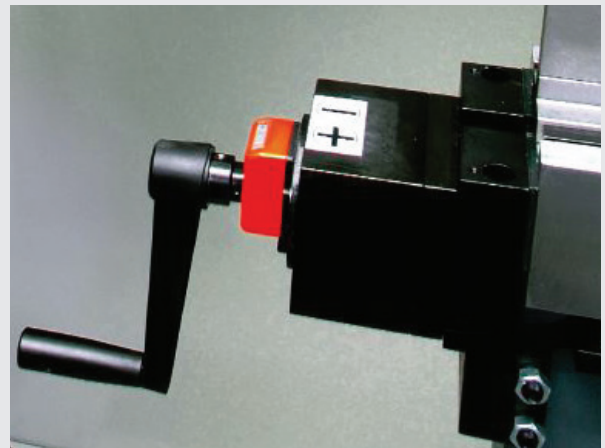

### CNC CROWNING

Motorised CNC controlled anti-deflection table for European Standard and single V-dies

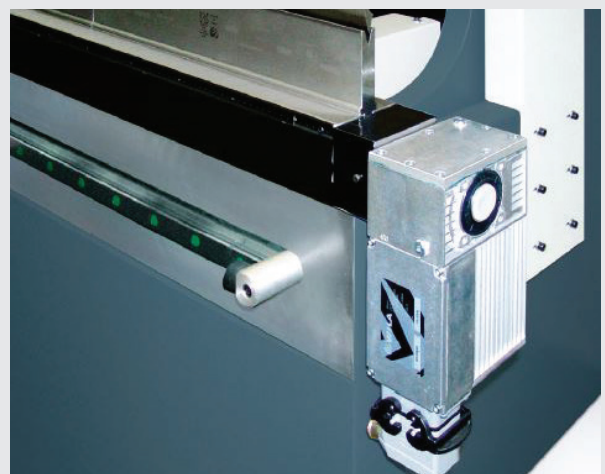

# SynchroMaster

## Optional equipment

### FRONT STOP TYPE I



### OPTICAL SAFETY GUARDS DSP AND FIESSLER AKAS® LC-II M

The CE regulation allows only Fast Approach Speed when applying an optical safety guard moving with the closing beam.

This guard is mounted to the beam and can be adjusted manually in height.

When detecting an obstacle within the protected area around the tip of the upper tooling, the system interrupts the downward movement instantaneously.

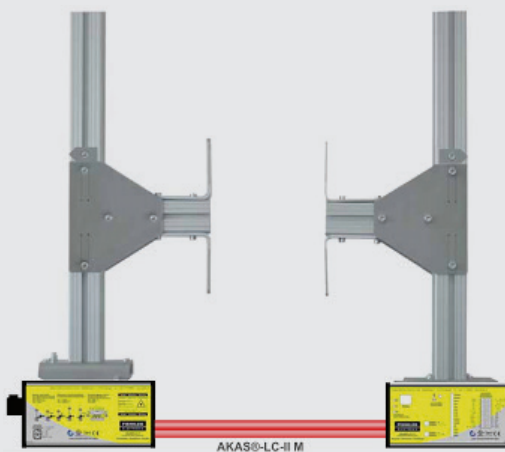

# EuroMaster-S Series

Your allround bending machine

## BEAM CONTROL

Beam parallelism and depth stop setting by means of bed referenced linear encoders for accurate beam position measurement, synchro module and proportional valve hydraulics

## INTUITIVE FASTBEND-2D MT PREMIUM CONTROL

- Multi Touch Technology on 21.5" screen
- Intuitive Operator Interface
- Smart Draft
- Multi-Tasking
- Step Previewer
- Combined Icons
- Auto Tooling
- Pendant arm with optional height adjustment

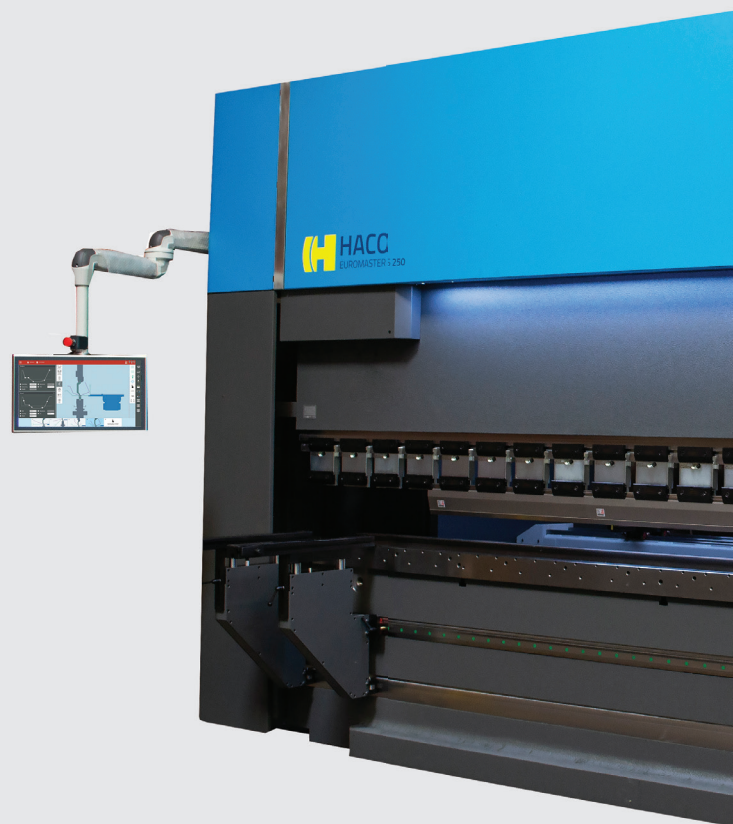
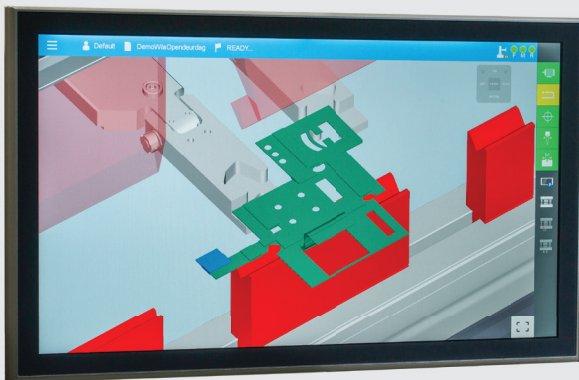

## EUROPEAN STANDARD TOP TOOLING WITH QUICK MANUAL CLAMPING

Picture: New Standard Top and Bottom Tooling (optional)

# EuroMaster-S Series



## CROWNING TABLE

Compensates for ram and table deflection, ensuring consistent bending angles over the entire bending length. Standard CNC controlled (V-axis).

## 2-AXES X-R BACKGAUGE

Rigid and High Speed backgauge for accurate sheet positioning

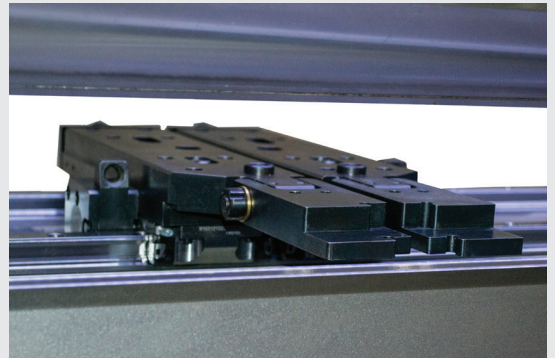

## 2 SHEET SUPPORTS WITH GUIDING



*Model 40250*

*Flush Floor frame  
design for all models*

# EuroMaster-S Series

## Standard Execution

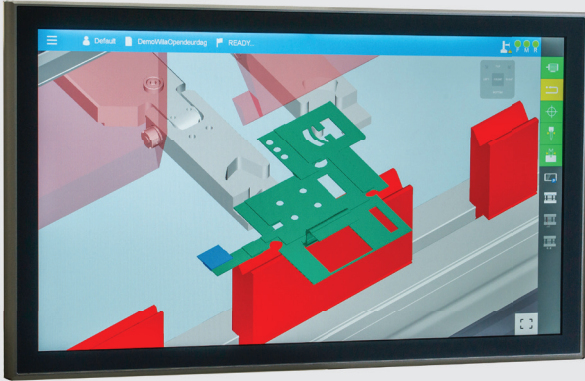

### INTUITIVE FASTBEND-2D MT PREMIUM CONTROL

The application of Multi Touch technology reduces the number of keyboard- and button actions to an absolute minimum. The innovative Smart Draft, Design/Bending Multitasking, Step Previewer and Combined Icons features allow the operator a straightforward, intuitive control of the entire production cycle.

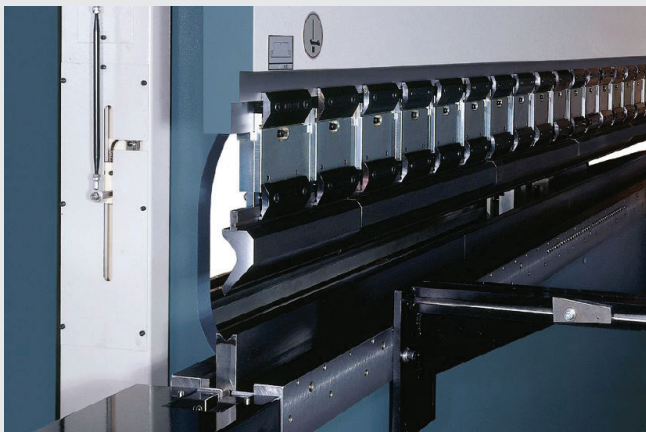

### EUROPEAN STANDARD (ES) TOP TOOLING with

Quick Manual Clamping arrangement and CNC controlled Anti Deflection Table with clamping for ES dies

The European Standard Tooling System has proven its flexibility, affordability and precision during the last decades in an infinite number of sheet metal working shops. A wide choice of a vast number of top and bottom tools allows for an unpredictable number of applications in various materials and thicknesses.



### HIGH SPEED X-R-BACKGAUGE

A rigid and accurate backgauge is an absolute condition for precision. High speed is an absolute condition for production output and short cycle times. The EuroMaster's X-R backgauge (and optional X-R-Z/Z' and X-R-Z1-Z2 versions) offers both. Manual finger width adjustment from the front.

# EuroMaster-S Series

## Standard Execution

- **FastBEND-2D MT Premium control**

Smart Draft + MultiTasking + Step Previewer + Combined Icons + Auto Tooling

21.5" Multi Touch screen

- **High Speed X-R Backgauge for accurate sheet positioning**

Stroke X = 800mm, speed = 1000mm/s

Stroke R = 250mm, speed = 250mm/s

- **European Standard (ES) top clamping with Quick Manual Clamping Arrangement**

- **Intermediate clamping with height 150mm (all models  $\leq$  3200 kN),  
height 120mm HD version ( all models = 4000 kN)**

- **CNC controlled Anti Deflection Table (Crowning) for ES dies, including nute for clamping single-V dies**

- **2 Sheet Supports 750 mm with guiding, manually adjustable in height**

- **LED illumination of the bending area**

## Your Competitive Edge

**A. Outstanding Price-Performance Ratio**

**B. State-Of-The-Art User Friendly 2D Multi Touch Control**

**C. Highest Part Precision**

# EuroMaster-S Series

## Technical Specifications

Daylight Opening - Stroke - Gap

	Basic European Standard (ES)			Option ES High Specs			Option New Standard (NS)			Option NS High Specs		
	Daylight Opening		GAP	Daylight Opening	STROKE	GAP	Daylight Opening	STROKE	GAP	Daylight Opening	STROKE	GAP
	D	E	C	D	E	C	D	E	C	D	E	C
	mm	mm	mm	mm	mm	mm	mm	mm	mm	mm	mm	mm
750 kN	520	270	400	620	370	400	440	270	400	540	370	400
1000 kN	520	270	400	620	370	400	440	270	400	540	370	400
1500 kN	520	270	400	620	370	400	440	270	400	540	370	400
2000 kN	520	270	400	620	370	400	440	270	400	540	370	400
2500 kN	520	270	400	620	370	400	440	270	400	540	370	400
3200 kN	620	420	400	-	-	-	540	420	400	-	-	-
4000 kN	620	420	400	-	-	-	540	420	400	-	-	-

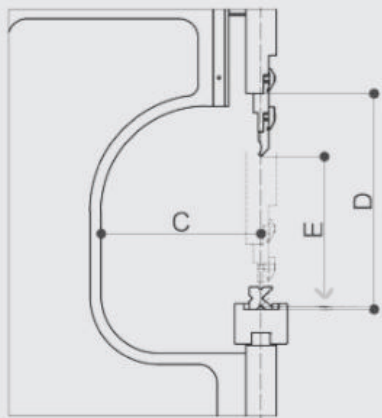

**EUROPEAN  
STANDARD**

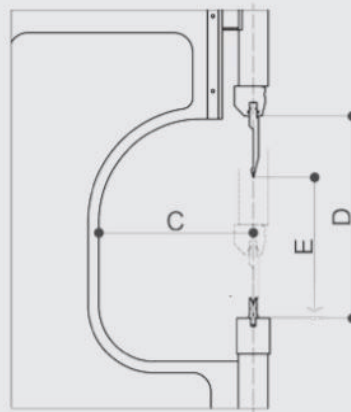

**NEW  
STANDARD**

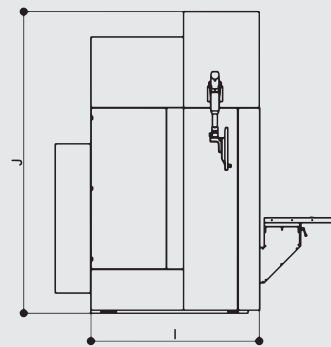
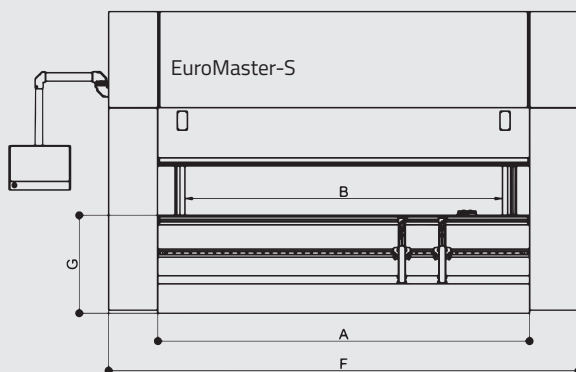



# EuroMaster-S Series

## Technical Specifications

(Valid for Basic European Standard)

	Bending length	Capacity	Distance between housings	Table Height	Fast Approach Speed	Max. Bending Speed	Fast Return Speed	Motor Power	Length	Width	Height	Weight
	A		B	G					F	I	J	
MODEL	mm	kN	mm	mm	mm/s	mm/s	mm/s	kW	mm	mm	mm	kg
20075	2100	750	1600	920	150	10	100	11	3230	1585	2920	5900
25075	2600	750	2100	920	150	10	100	11	3730	1585	2920	7100
30075	3100	750	2600	920	150	10	100	11	4230	1585	2920	8000
25100	2600	1000	2100	920	200	10	125	11	3730	1585	2920	7500
30100	3100	1000	2600	920	200	10	125	11	4230	1585	2920	8100
36100	3660	1000	3150	920	200	10	125	11	4640	1585	2920	10500
40100	4100	1000	3150	920	200	10	125	11	5230	1585	2920	10800
43100	4300	1000	3750	920	200	10	125	11	5416	1585	2920	12100
25150	2600	1500	2100	920	200	10	125	15	3730	1705	2920	8100
30150	3100	1500	2600	920	200	10	125	15	4230	1705	2920	9700
36150	3660	1500	3150	970	200	10	125	15	4640	1705	2920	11600
40150	4100	1500	3150	970	200	10	125	15	5230	1705	2920	12000
43150	4300	1500	3750	970	200	10	125	15	5416	1705	2920	13500
25200	2600	2000	2100	920	200	8	120	18.7	3730	1820	2920	10700
30200	3100	2000	2600	920	200	8	120	18.7	4230	1820	2920	11900
36200	3660	2000	3150	920	200	8	120	18.7	4640	1820	2920	12800
40200	4100	2000	3150	920	200	8	120	18.7	5230	1820	2920	13500
43200	4300	2000	3750	920	200	8	120	18.7	5416	1820	2920	16800
30250	3100	2500	2600	895	130	8	90	18.7	4230	2020	2920	13900
36250	3600	2500	3150	895	130	8	90	18.7	4640	2020	2920	15400
40250	4100	2500	3150	895	130	8	90	18.7	5230	2020	2920	15800
43250	4300	2500	3750	895	130	8	90	18.7	5416	2020	2920	17100
50250	5000	2500	4050	945	130	8	90	18.7	5460	2025	3490	24300
60250	6000	2500	5050	1090	130	8	90	18.7	6460	2025	3490	31000
30320	3100	3200	2600	895	100	8	95	22.5	4100	2025	3490	17500
36320	3660	3200	3150	895	100	8	95	22.5	4700	2025	3490	20000
40320	4100	3200	3150	895	100	8	95	22.5	5100	2025	3490	21500
43320	4300	3200	3750	895	100	8	95	22.5	5300	2025	3490	23500
50320	5000	3200	4050	940	100	8	95	22.5	5460	2025	3490	28000
60320	6000	3200	5050	1095	100	8	95	22.5	6460	2025	3490	33000
30400	3100	4000	2600	1045	90	7	60	37.5	4100	2270	3950	26500
36400	3660	4000	3150	1045	90	7	60	37.5	4660	2270	3950	29500
40400	4100	4000	3150	1045	90	7	60	37.5	5100	2270	3950	31500
43400	4300	4000	3150	1045	90	7	60	37.5	5300	2270	3950	32000

Specifications subject to modifications without price notice

# PressMaster Series

Your High Spec, High Performance bending machine

**INCREASED DAYLIGHT OPENING (540MM),  
STROKE (370MM)**

## BEAM CONTROL

Beam parallelism and depth stop setting by means of bed referenced linear encoders for accurate beam position measurement, synchro module and proportional valve hydraulics

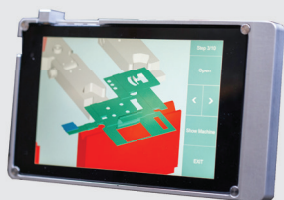

**SyncView**

## INTUITIVE FASTBEND-3D MT PREMIUM CONTROL

- Multi Touch Technology on 24" screen
- Intuitive Operator Interface
- Smart Draft
- Multi-Tasking
- Step Previewer
- Combined Icons
- Auto Tooling
- PartManager-3D



**NEW STANDARD HYDRAULIC TOP TOOL CLAMPING**

**LAZERSAFE OPTICAL SAFETY GUARD (optional)**

# PressMaster Series



## CNC CROWNING TABLE WITH HYDRAULIC CLAMPING FOR NEW STANDARD BOTTOM TOOLING

Compensates for ram and table deflection, ensuring consistent bending angles over the entire bending length.  
CNC controlled (V-axis)

## 4-AXES X-R-Z1-Z2 BACKGAUGE

Rigid and High Speed backgauge for accurate sheet positioning

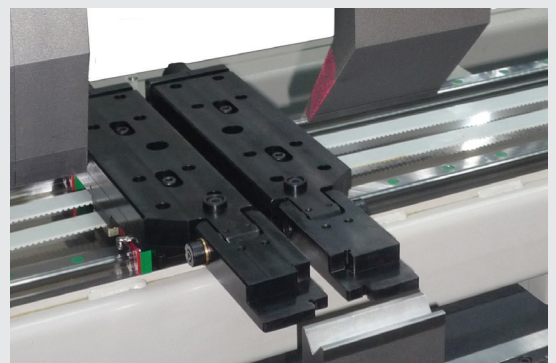

## 2 SHEET SUPPORTS WITH GUIDING



*Model 36150  
Flush Floor frame  
design for all models*

# PressMaster Series

## Standard Execution

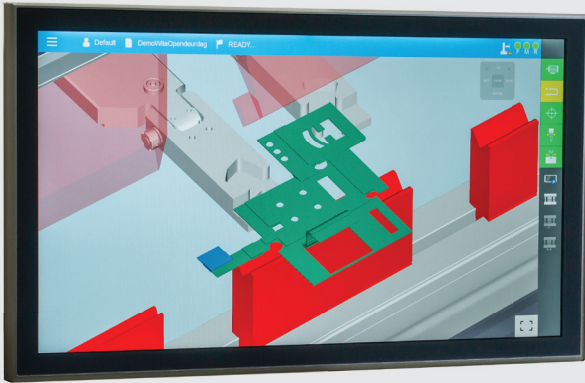

### INTUITIVE FASTBEND-3D MT PREMIUM CONTROL

The application of Multi Touch technology reduces the number of keyboard- and button actions to an absolute minimum. The innovative Smart Draft, Design/Bending Multitasking, Step Previewer and Combined Icons features allow the operator a straightforward, intuitive control of the entire production cycle.

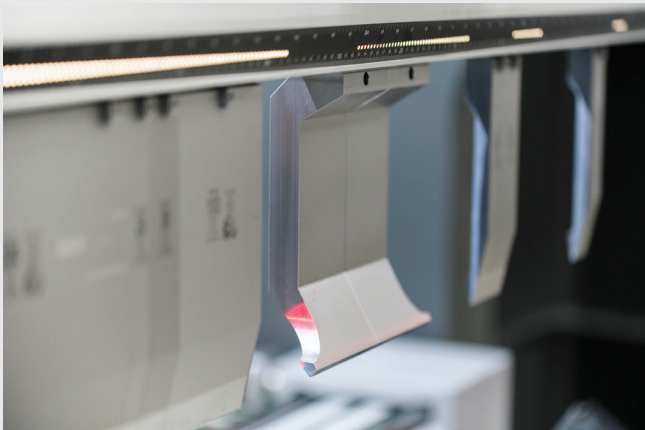

### NEW STANDARD (NS) hydraulic top tool clamping and CNC controlled Anti Deflection Table with hydraulic bottom tool clamping

The New Standard Tooling System has proven its flexibility and precision during the last decades in an infinite number of sheet metal working shops. A wide choice of a vast number of top and bottom tools allows for a unpredictable number of applications in various materials and thicknesses.

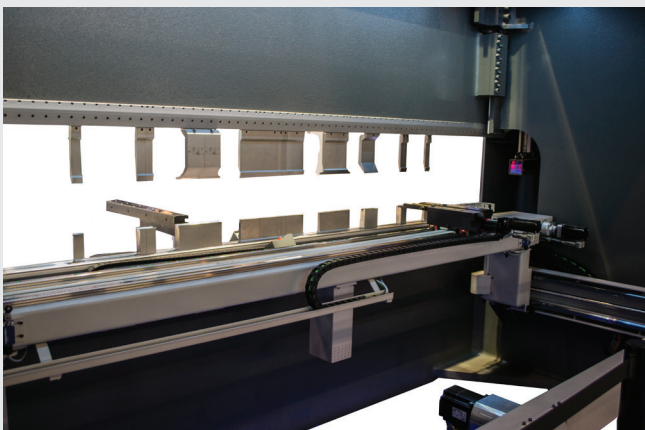

### HIGH SPEED X-R-Z1-Z2 BACKGAUGE

A rigid and accurate backgauge is an absolute condition for precision. High speed is an absolute condition for production output and short cycle times. The PressMaster's X-R-Z1-Z2 backgauge offers both.

# PressMaster Series

## Standard Execution

- **FastBEND-3D MT Premium control**
  - Smart Draft + MultiTasking + Step Previewer + Combined Icons + Auto Tooling + Part Manager-3D
  - 24" Multi Touch screen
- **Increased Daylight Opening (540mm), Stroke (370mm) and Gap (400mm)**
- **Increased Fast Approach Beam Speed (up to 200mm/s) and Fast Return Speed (up to 170mm/s)**
- **High Speed X-R-Z1-Z2 Backgauge for accurate sheet positioning**
  - Stroke X = 800mm, speed = 1000mm/s
  - Stroke R = 250mm, speed = 250mm/s
  - Speed Z1 and Z2 axes = 1000mm/s
- **New Standard (NS) hydraulic top tool clamping**
- **CNC controlled Anti Deflection Table (Crowning) for NS dies**
- **2 Sheet Supports with guiding, manually adjustable in height**
- **LED illumination of the bending area**
- **Less Power Consumption through application of Variable Inverter Drive (= VID) for motor-pump unit.**

The VID technology allows for higher beam return speeds in combination with 'no power consumption with stationary beam.

## Your Competitive Edge

**A. Ultimate Price-Quality Ratio**

**B. State-Of-The-Art User Friendly 3D Multi Touch Control**

**C. Lowest Cycle Times**

# PressMaster Series

## Technical Specifications

	Bending length	Capacity	Distance between housings	Gap	Daylight opening	Stroke	Table Height	Fast Approach Speed	Max. Bending Speed	Fast Return Speed	Motor Power	Length	Width	Height	Weight
	A		B	C	D	E	G					F	I	J	
MODEL	mm	kN	mm	mm	mm	mm	mm	mm/s	mm/s	mm/s	kW	mm	mm	mm	kg
20075	2040	750	1600	400	540	370	920	200	10	150	11	3230	1585	2980	6000
25075	2550	750	2100	400	540	370	920	200	10	150	11	3730	1585	2980	6800
30075	3060	750	2600	400	540	370	920	200	10	150	11	4230	1585	2980	8200
25100	2550	1000	2100	400	540	370	920	200	10	170	11	3730	1585	2980	8100
30100	3060	1000	2600	400	540	370	920	200	10	170	11	4230	1585	2980	9600
36100	3655	1000	3150	400	540	370	920	200	10	170	11	4640	1585	2980	10400
40100	4080	1000	3150	400	540	370	920	200	10	170	11	5230	1585	2980	11200
43100	4250	1000	3750	400	540	370	920	200	10	170	11	5416	1585	2980	12800
25150	2550	1500	2100	400	540	370	920	200	10	170	15	3730	1705	2980	8700
30150	3060	1500	2600	400	540	370	920	200	10	170	15	4230	1705	2980	10300
36150	3655	1500	3150	400	540	370	970	200	10	170	15	4640	1705	2980	12600
40150	4080	1500	3150	400	540	370	970	200	10	170	15	5230	1705	2980	13100
43150	4250	1500	3750	400	540	370	970	200	10	170	15	5416	1705	2980	14600
25200	2550	2000	2100	400	540	370	920	200	8	170	18.7	3730	1820	2980	10800
30200	3060	2000	2600	400	540	370	920	200	8	170	18.7	4230	1820	2980	12000
36200	3655	2000	3150	400	540	370	920	200	8	170	18.7	4640	1820	2980	13100
40200	4080	2000	3150	400	540	370	920	200	8	170	18.7	5230	1820	2980	13800
43200	4250	2000	3750	400	540	370	920	200	8	170	18.7	5416	1820	2980	17000
30250	3060	2500	2600	400	540	370	895	130	8	90	18.7	4230	2020	2980	14900
36250	3655	2500	3150	400	540	370	895	130	8	90	18.7	4640	2020	2980	15800
40250	4080	2500	3150	400	540	370	895	130	8	90	18.7	5230	2020	2980	16400
43250	4250	2500	3750	400	540	370	895	130	8	90	18.7	5416	2020	2980	17900

Specifications subject to modifications without price notice

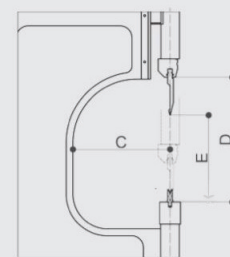
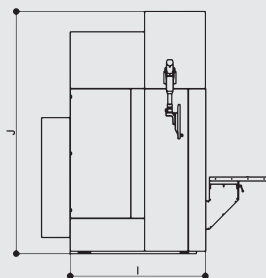
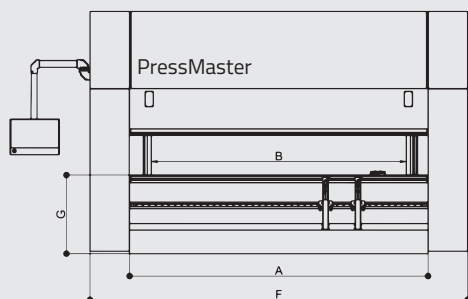

NEW STANDARD

# Backgauges

## Standard and optional

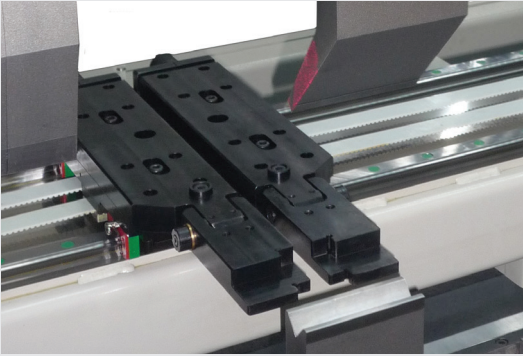

### X-R-Z1-Z2 (standard)

Stroke **X** = 800 mm

Max. Speed **X** = 1000 mm/s

Stroke **R** = 250 mm

Max. Speed **R** = 250 mm/s

Max. Speed **Z1-Z2** = 1000 mm/s



### X-R-Z1-Z2-X3 (optional)

Stroke **X** = 800 mm

Max. Speed **X** = 1000 mm/s

Stroke **R** = 250 mm

Max. Speed **R** = 250 mm/s

Max. Speed **Z1-Z2** = 1000 mm/s

Stroke **X3** = -50/+50 mm

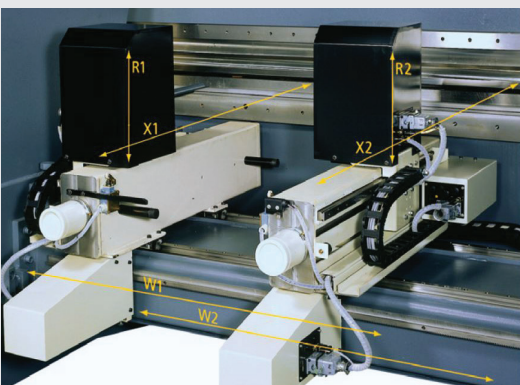

### X1-X2-R1-R2-W1-W2 (optional)

Stroke **X1-X2** = 600 mm

Stroke **R1-R2** = 100 mm ( $\leq 1500$  kN)

= 135 mm ( $> 1500$  kN)

# FastBEND-2D/3D MT Premium

## Intuitive Bending

The **FastBEND-2D/3D MT Premium** Controls set a new standard in the market for flexible, reliable and high precision sheet metal bending.

Driven by **state-of-the-art PC-based hardware**, the system allows for very fast data processing and highly accurate calculation of the optimal bending programs for hydraulic CNC press brakes.

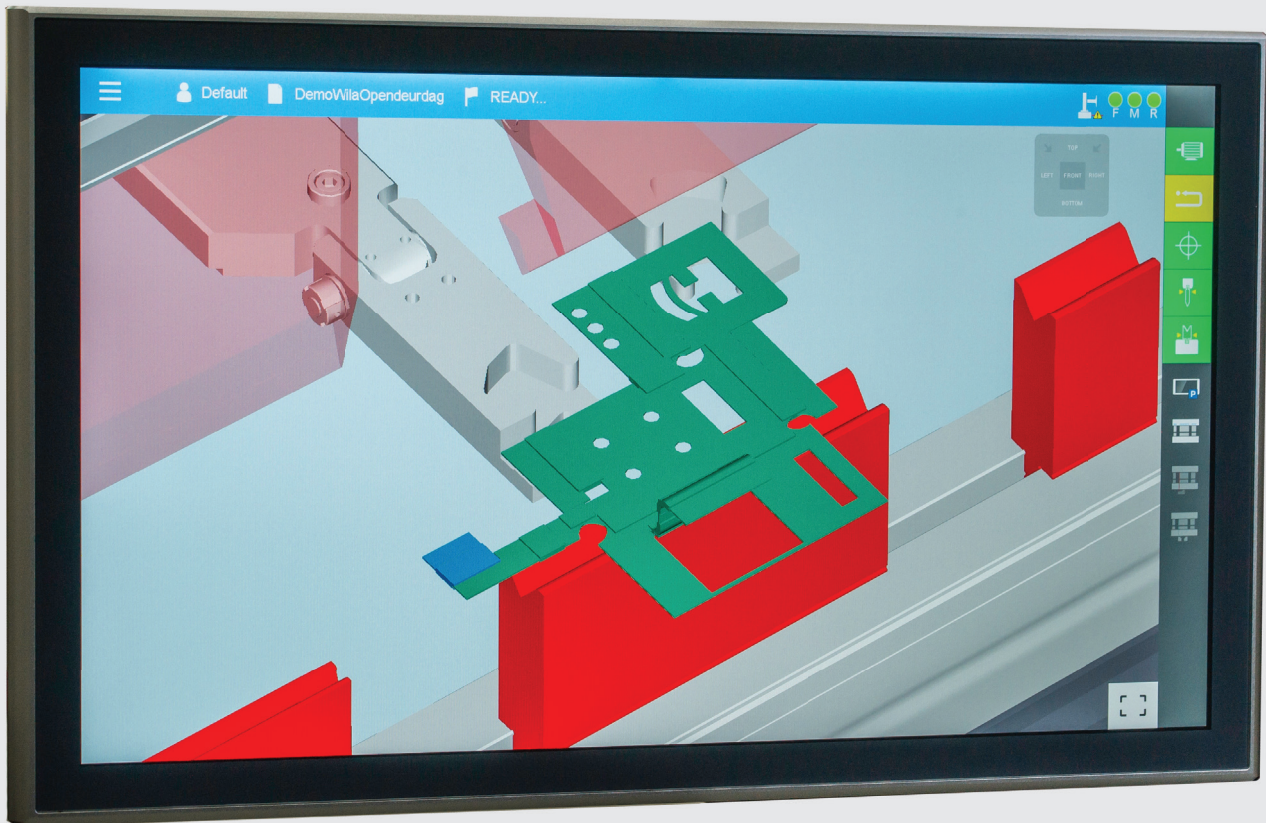



# FastBEND-2D/3D MT Premium

## Intuitive Bending

**Intuitive Interface** with a minimum of interactions to draw the workpiece and generate the corresponding program

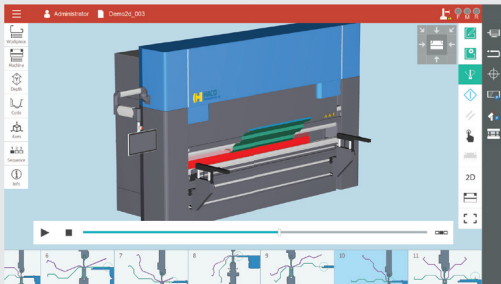

Multi Touch Technology on  
**24" screen** (FastBEND-3D MT Premium)  
**21,5" screen** (FastBEND-2D MT Premium)

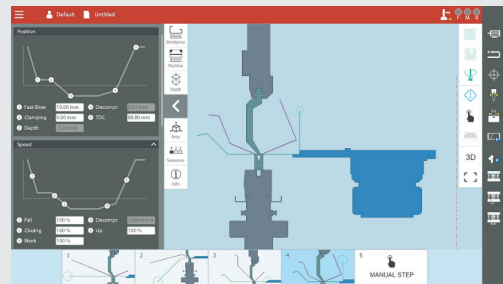

**Intuitive Interface** with combined numerical-graphical user interface

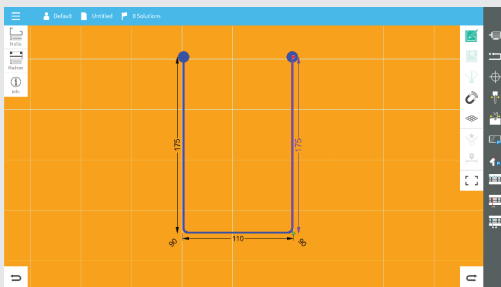

**MULTITASKING** : Workpiece drawing with instantaneous collision detection and calculation of the bending sequence in the background

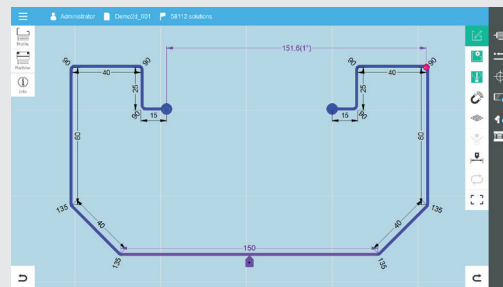

**SMART DRAFT** : Innovative drawing method for generating 2D workpieces

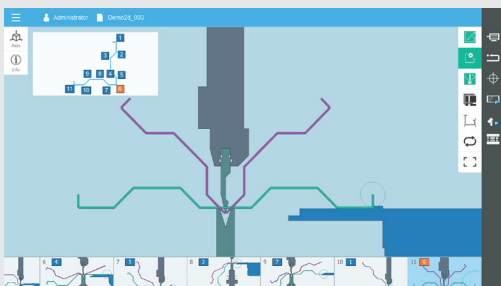

**STEP PREVIEWER** : bar with possibility of horizontally scrolling of the bending steps

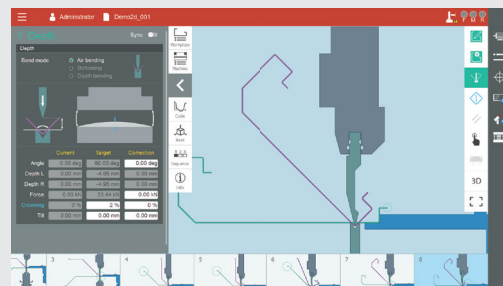

**COMBINED ICONS** : multiple functionalities by means of one single icon

# New Standard Tooling System

Standard for PressMaster, Optional for EuroMaster-S

Wila's **'New Standard' Tooling System** has become market leader for precision, quality and flexibility. The selfseating and selfaligning features considerably improve your set up times and productivity of your pressbrake. Both bottom (OZU) and top (BIU) tooling are clamped hydraulically. The bottom clamping is integrated in the crowning table.

New Standard tooling is safe: the Safety-Click system (for top tools up to 12,5 kg) enables vertical loading and unloading of your top tooling without any risk. For tools with bigger weight, a safety pin or key is applied.

Working surfaces and bending radii of New Standard tooling are hardened and precision ground for maximum longevity.

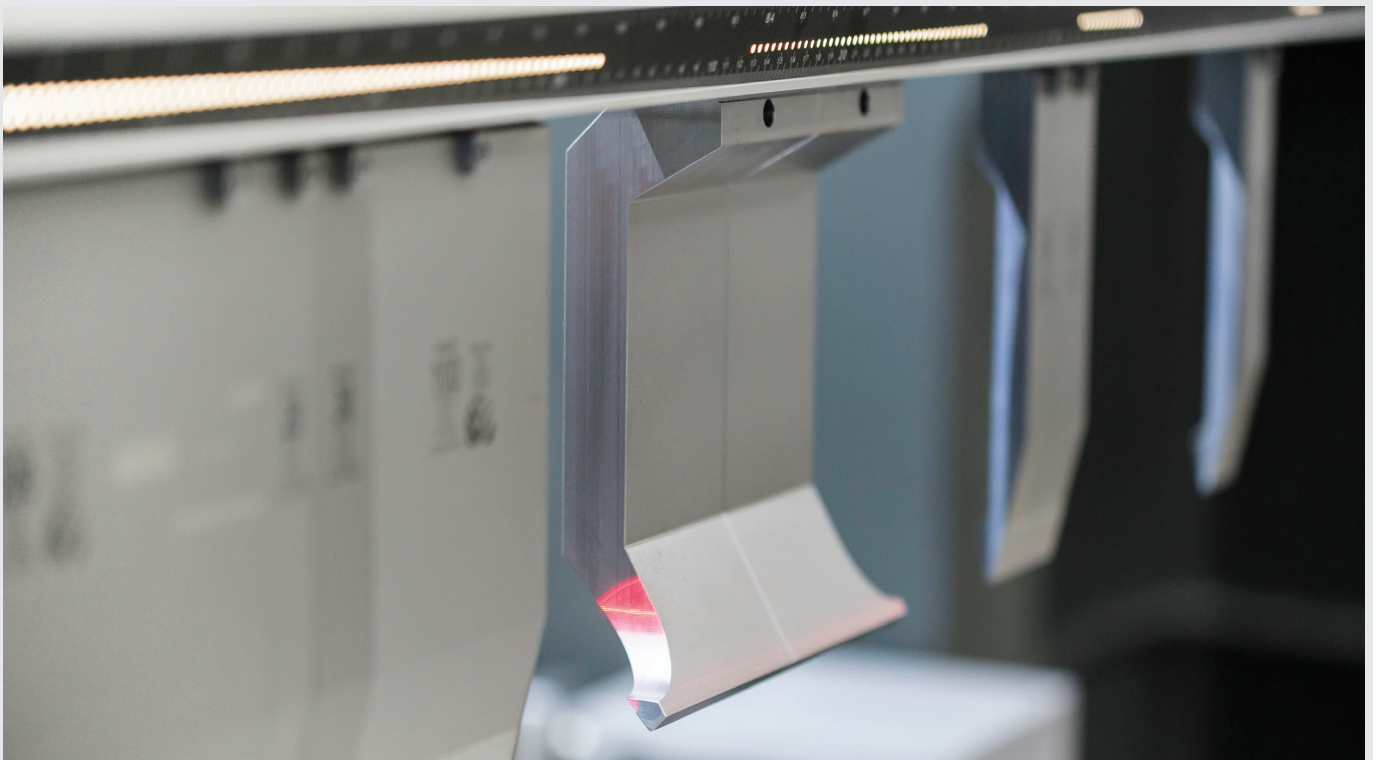

## MAIN BENEFITS

**1. Vertical loading and unloading**

**2. Self-seating and self-aligning**

**3. High precision and longevity**

---

# Optional Smart Tool Locator

## Increase your pressbrake productivity

The **Smart Tool Locator (STL)** further increases your pressbrake productivity. The system indicates by means of built-in LED's the right clamping position of your tooling during tool set up and indicates the active tool location in production mode. The Smart Tool Locator offers significant benefits in **speed, precision** and **flexibility**.

Available for all hydraulic New Standard Tool Holders for top and bottom tools.



### NEW STANDARD PREMIUM AND PRO TOOLING

Both top (BIU) and bottom (OZU) tools are available in a wide variety of shapes and dimensions. For more detailed information, see the New Standard Tooling Catalogue.

Available for all hydraulic New Standard Tool Holders for top and bottom tools.

# Lazersafe Optical Safety Guards

## Advanced Safety

CE Safety Regulations require the application of an **Optical Safety Guard (OSG)** when operating at closing speed.

Optical modules (transmitter and receiver) mounted to the ram of the machine monitor the downward movement in the area underneath the top tooling tip. During the fast closing speed, the beam movement is instantaneously stopped when the system detects an obstacle.

EuroMaster-S and PressMaster can be equipped with **LazerSafe LZS-LG-HS** with mute point 6mm (RapidBend) or with **LazerSafe IRIS** (RapidBend Ultimate) with mute point 0 mm.

### BOTH SYSTEMS GUARANTEE

a high level of safety for the operator

a high level of machine productivity

security against tooling collision at high speeds

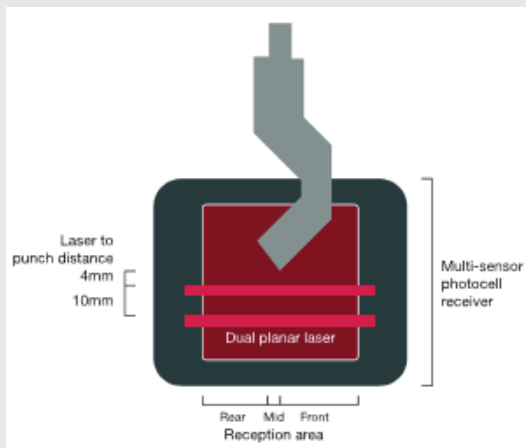

Lazersafe LZS-L6-HS

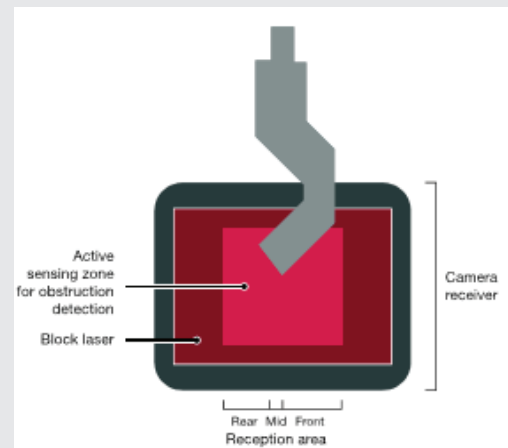

Lazersafe IRIS



EMS



PM

# Lazersafe Optical Safety Guards IRIS

## Features

- Optimal Speed Change Over Point
- Fast Closing Speed in safe conditions (monitoring till mute point 0 mm)
- Faster cycle times
- Ultimate Operator Safety
- Security against tooling damage
- Full Integration in the CNC System
- Automatic Alignment

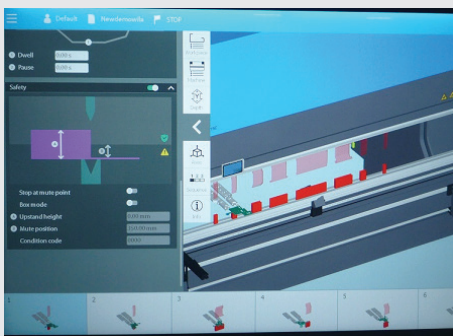

### NORMAL MODE

All sensors + 3 zones active  
Fast Approach Speed till mute punt  
Followed by Working Speed  
(unless interruption by obstacle)



### BOX MODE WITH PROGRAMMABLE FLANGE HEIGHT

Programmable flange height  
Extra deliberately foot pedal command  
Front and Rear zone switched off at flange height



### MUTE STOP MODE

Applicable for workpieces with flanges which interrupt the monitored zone in normal mode operation.  
Initial fast approach till mute point, consequently operator infeed of the workpiece.

# Angle Measuring System Alfa-F

## Angle Measurement



EMS



PM

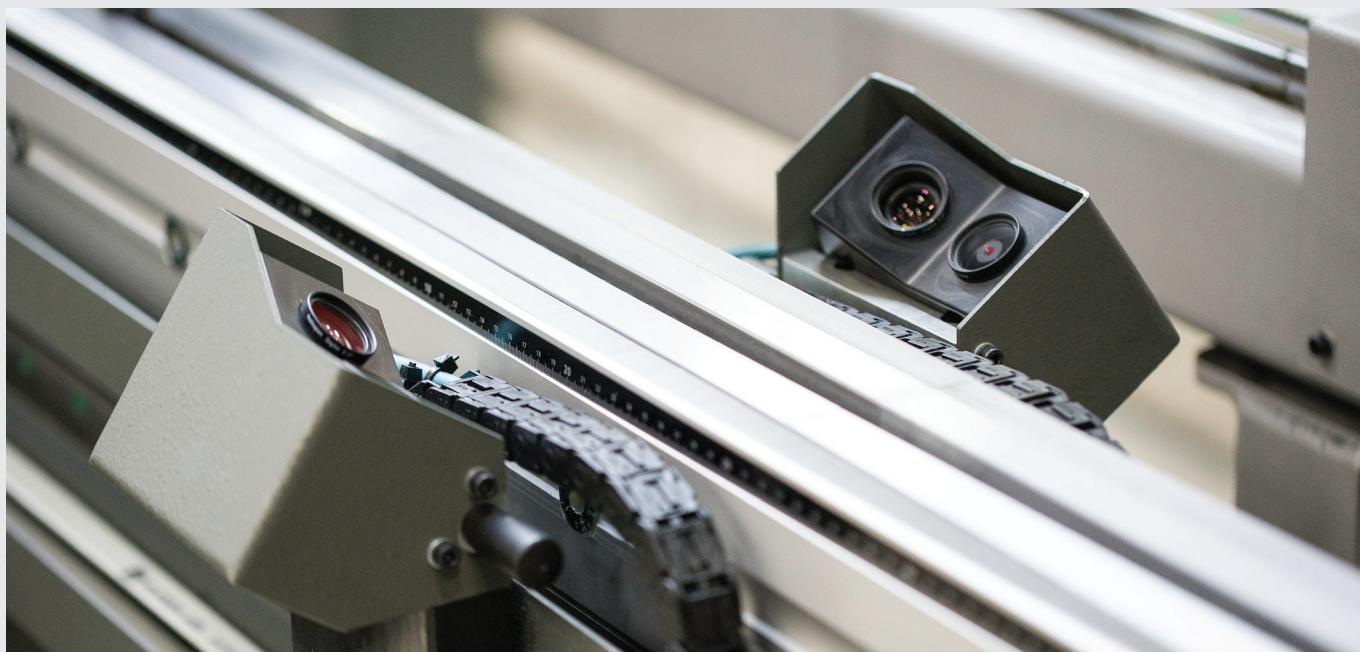

System consisting of 2 laser beam transmitters and 2 camera's on both sides of the workpiece.

Principle :

**Angle Measurement**

**Force reduction + calculation of the springback**

**Automatic angle correction (taking into account the calculated springback)**

## FEATURES ALFA-F

- Different V-openings and dies are applicable, preferable single-V's with minimal height of 100mm
- Quick manual adjustment along the machine length (optional CNC-positioning)
- Optional parking station if system is not in operation

---

## FEATURES ALFA-F AND IRIS PLUS

- Standard tooling is applicable - no extra cost for internal measuring units
- No contact elements - no mechanical wear
- Contactless angle measurement principle guarantees a reliable system even in heavy duty circumstances.



EMS



PM

# Angle Measuring System IRIS Plus

## Angle Measurement

Automatic angle measurement and automatic correction of the bending angle



*Active Angle control is a highly accurate angle control process that calculates spring back for each individual bend, then controls the bend depth with Live Angle Bending to achieve the correct angle.*

IRIS Plus comprises a laser transmitter and receiver set mounted to the upper beam of the press brake. It includes a high speed digital camera and image data processing system contained within the receiver unit.

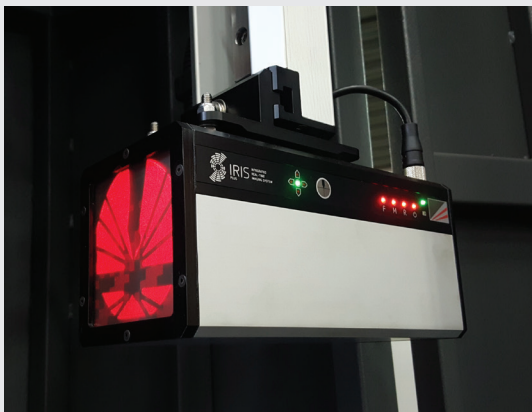

### FEATURES IRIS PLUS

- Different V-openings (8 until 35 mm) and dies are applicable, only single V-'s
- Recommendable limitation on the working length: ca. 3600 mm
- Most optimal accuracy results (3 meters or less)
- Never collision with workpiece

---

### FEATURES ALFA-F AND IRIS PLUS

- Compact assembly guarantees an optimal working space for operator and material
- Possibility of measuring on workpieces with apertures
- Guaranteed precision

# Sheet Following Systems

For bending long and thin sheets

Sheet Following Systems are especially recommended when bending **long** and **thin** sheets as they support as well as prevent second bends in your part.

They are very efficient in **supporting heavy parts** during decompression and the beam return movement.

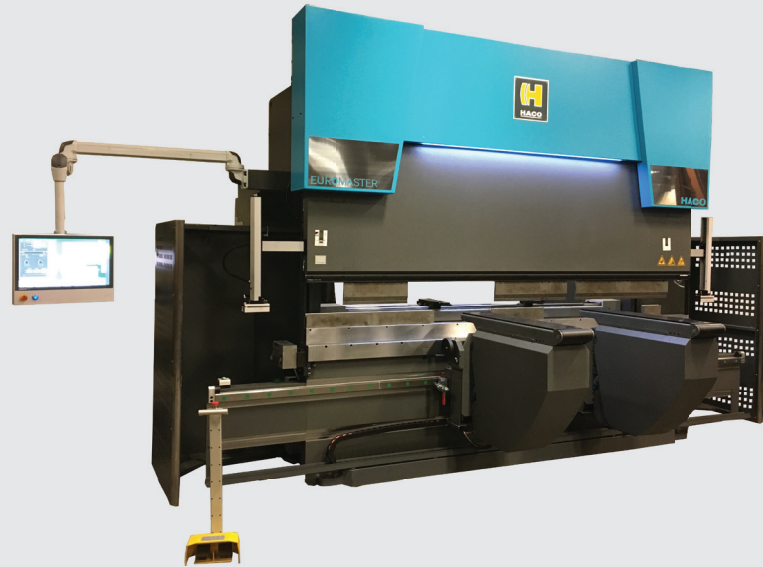

The Sheet Following Units are operating electro-mechanically by means of servo motors, with adjustable speed as a function of the applied V-opening.

They can be adjusted vertically in order to suit different die heights.

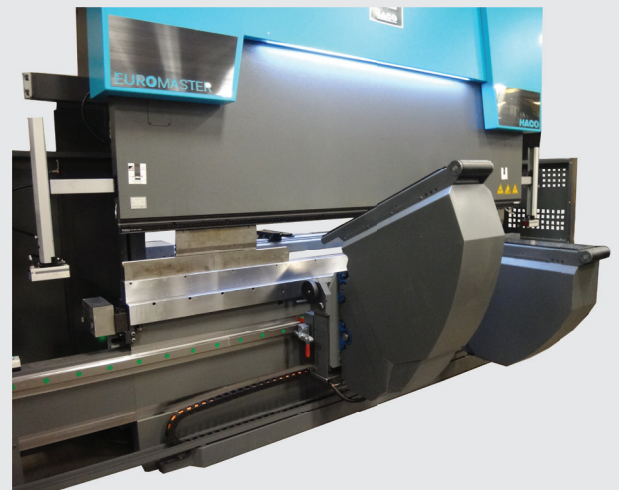
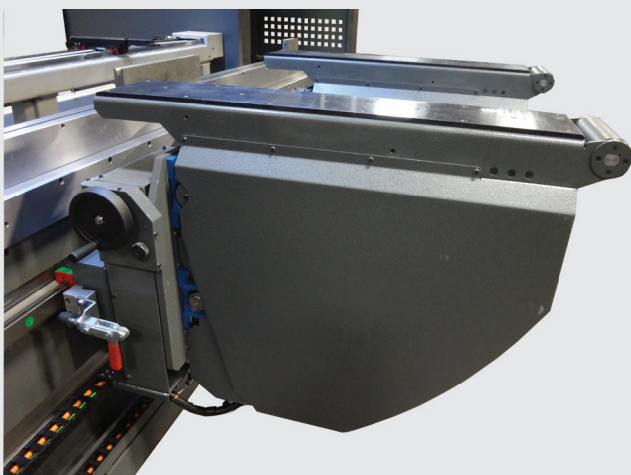





EMS



PM

# Sheet Following Systems

## Optional parking stations

Optional parking stations at right and/or left hand side of your pressbrake allow for parking your sheet following system when not operational. The system is moved out of the bending zone enhancing ergonomics and safety.

*Picture: control panel at the right hand side is optional*

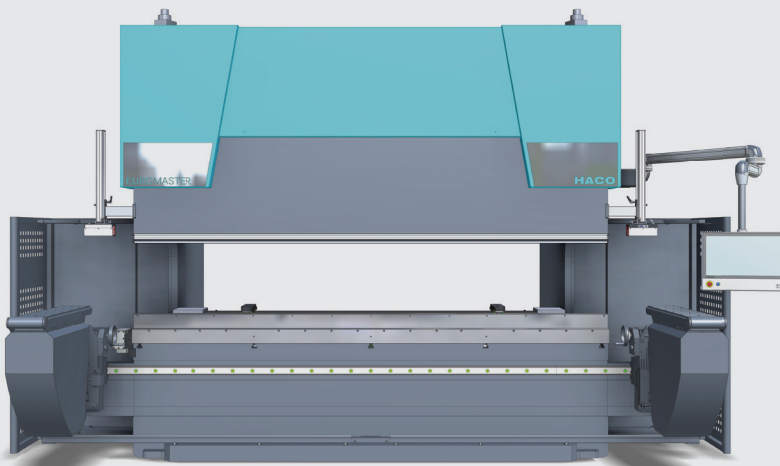

### Picture below:

Special Customized Sheet Following System with 1 telescopic arm inclusive width adjustment of the support surface and height adjustment of the following arm.

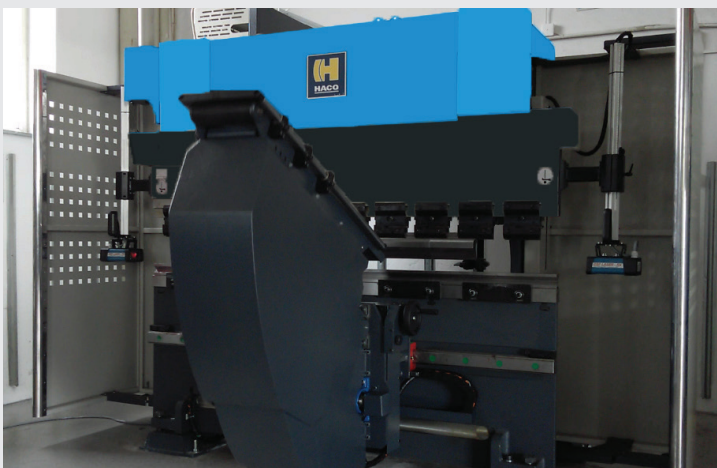

# SyncView

Human and machine become one

## SYNCVIEW: BENDING EFFICIENCY

SyncView was invented from the notion that it would be ideal to **watch both screen and workpiece simultaneously** during the bending process. This innovative solution consists of a tablet screen that is automatically positioned at the **optimal location**: where the piece is actually positioned by the operator.

## SYNCVIEW SPECIFICATIONS:

- 8" display
- fast, automated positioning to the correct tool location
- Multi-Touch interface
- automated wireless charging





**EMS**



**PM**

# SyncView

Human and machine become one

## SYNCVIEW'S ADVANTAGES

### Time-savings & efficiency

The operator no longer has to look at a fixed 3D image on the screen – sometimes meters away from him – time is no longer wasted when bending (complex) parts. With this innovation – in which the 3D image of the bending steps is always right in front of the user – he can understand and carry out the steps quicker during the bending sequence. In addition, the 3D images on the screen can be rotated, without the operator having to leave the work position. This enables an even better and faster evaluation of complex pieces than is possible from a single perspective. User tests indicate time-savings of up to 25% during the actual bending process.

### Ergonomics & physical comfort

The operator no longer has to constantly keep turning his head between the screen and the workpiece. Eliminating repetitive torsional movements of the neck and torso reduces long-term health risks. Now, the operator can look in the same direction at both the screen and the workpiece, which simply requires eye movement – producing a more pleasant, natural and comfortable interaction.

### Safety & user-friendliness

What's more, should something go wrong, the operator now recognizes it quickly. This is a safety benefit particularly when positioning the piece. The operator is no longer occupied either with the screen or with the workpiece. The workflow becomes one, so to speak – enabling the operator to focus 100% on the bending process itself.



Robot Bending



Fiber Laser Cutting

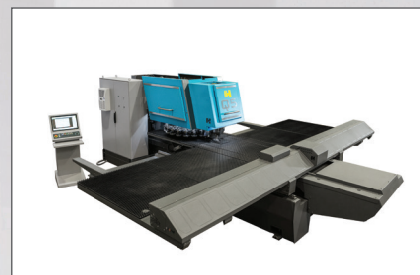

Punching

**HACO NV**  
Oekensestraat 120  
8800 Roeselare  
Belgium  
T +32 (0) 51 26 52 00  
E-Mail: info@haco.com  
www.haco.com

[WWW.HACO.COM](http://WWW.HACO.COM)

**SynchroMaster  
EuroMaster-S  
PressMaster**

*For Impressive Performances*