

# System X, XP

description of handling system

Handling system X and XP includes a wide range of roller conveyors, heavy length stops, feeders and accessories such as vertical rollers, preparatory tables, etc.



# Excellent price

Production line with gravity or semi-automatic band saw, powered conveyors and digital length stop on output.

- » **band saw**
- » **powered input conveyor**
- » **length stop**



XVR – vertical roller



Drive unit for conveyor XP

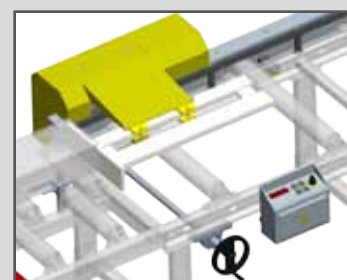

Digital material Length-stop with handwheel and pneumatic brake

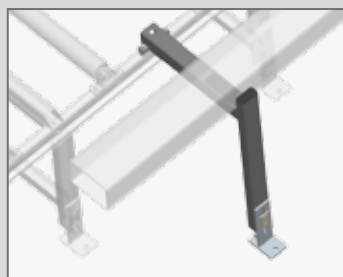
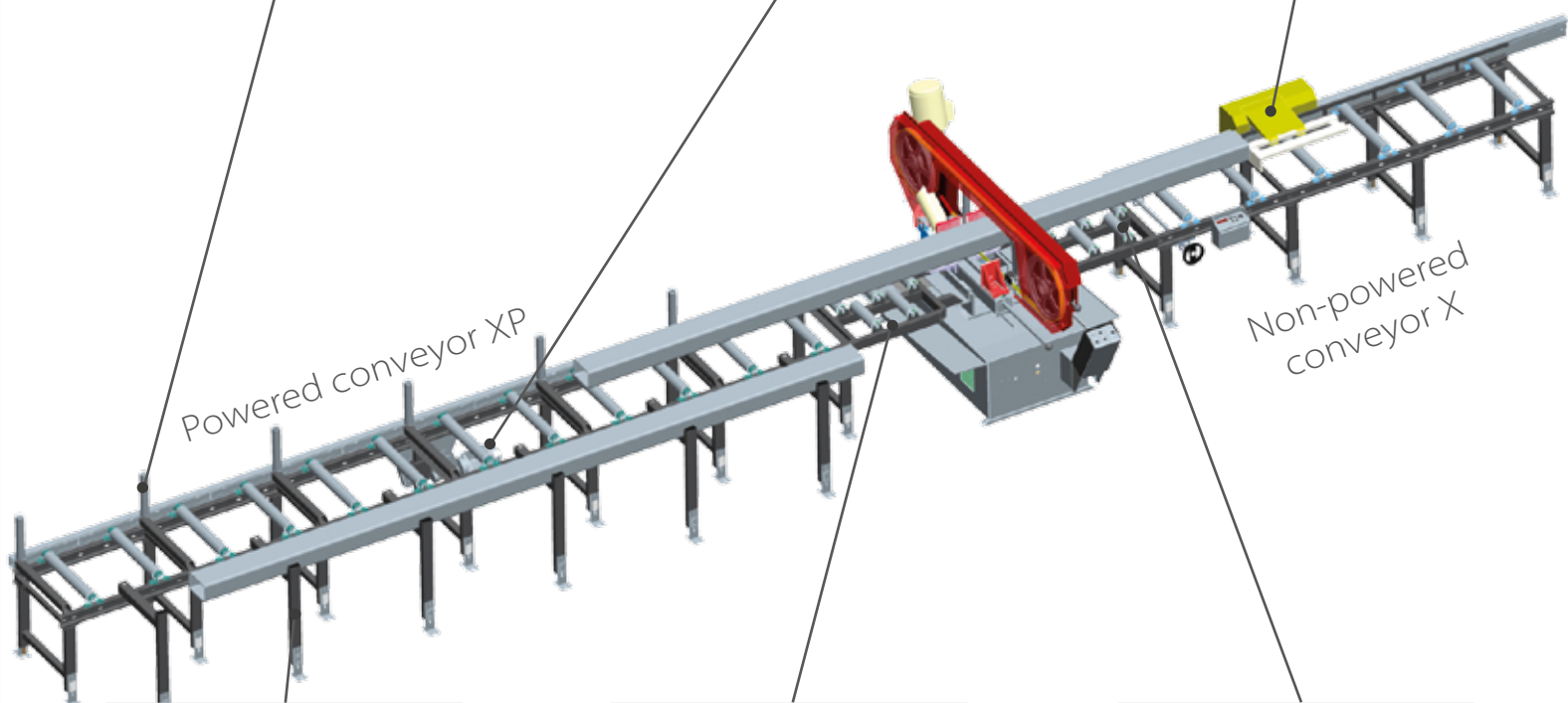

XEV – Preparative leg for material

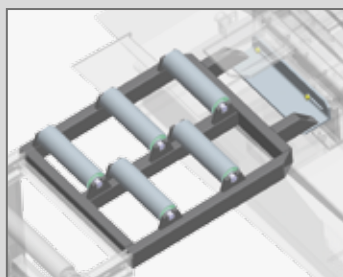

Left connecting part

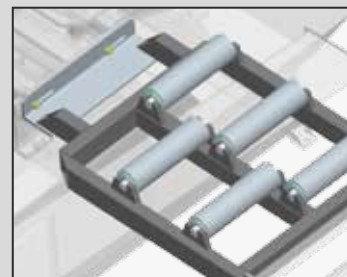

Right connecting part

# Productivity

Production line with semi-automatic band saw, not driven input and output conveyor and an automatic feeder.

- » semi-automatic band saw
- » non-powered conveyor
- » automatic feeder

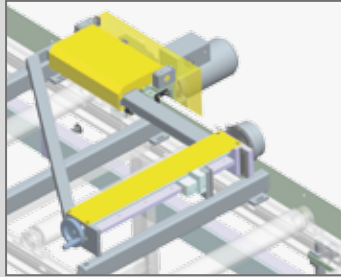

X-VL – Automatic feeder

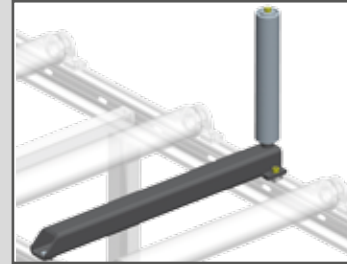

XVR – vertical roller

Non-powered conveyor X

Non-powered conveyor X



Left connecting part



Right connecting part

# Progressive handling system

Here is an example of a complete cutting center with semi-automatic band saw, long, fully driven input and output conveyors, cross feeder, heavy automatic material length stop and gateways. On request, we will prepare any cutting center that will meet your requirements.

- » semi-automatic band saw
- » long powered input conveyor
- » heavy length stop
- » cross feeders

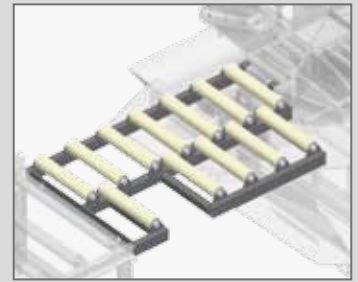

Left connecting part

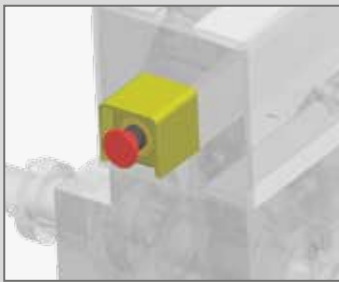

TOTAL-STOP

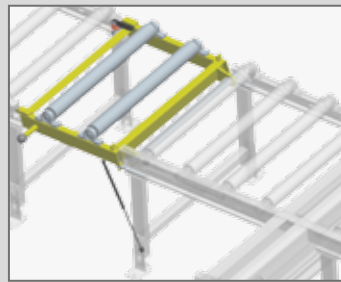

Gateway

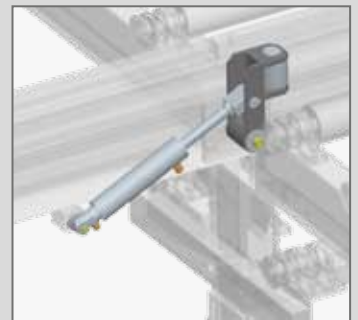
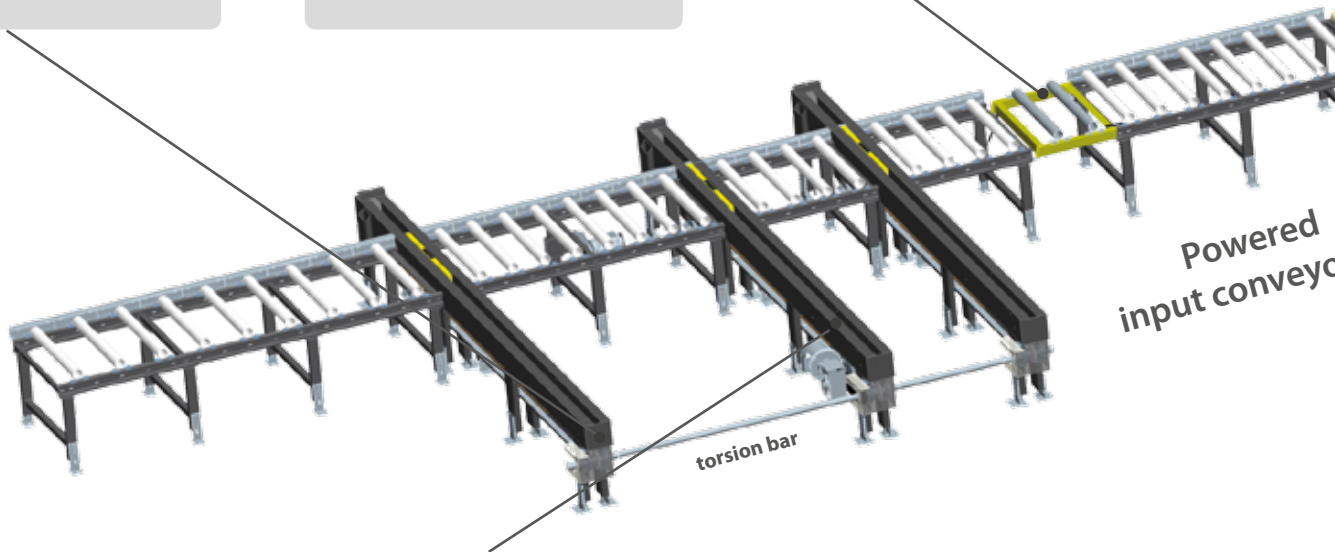

Cross feeder with front and rear unloading, drive unit and with vertical tilting rollers.



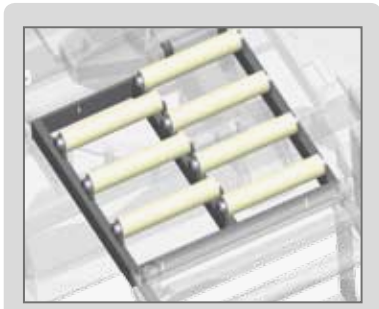

Right connecting part

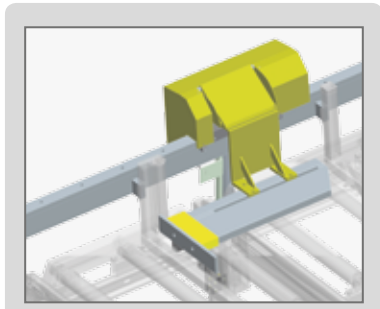

X-NCAS – heavy automatic material length stop

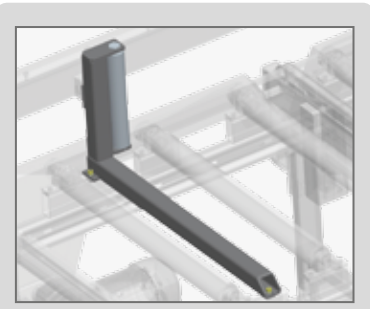

XVR-NC – vertical roller for length stop

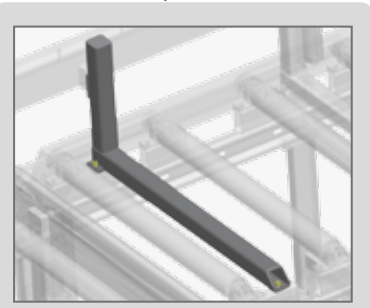
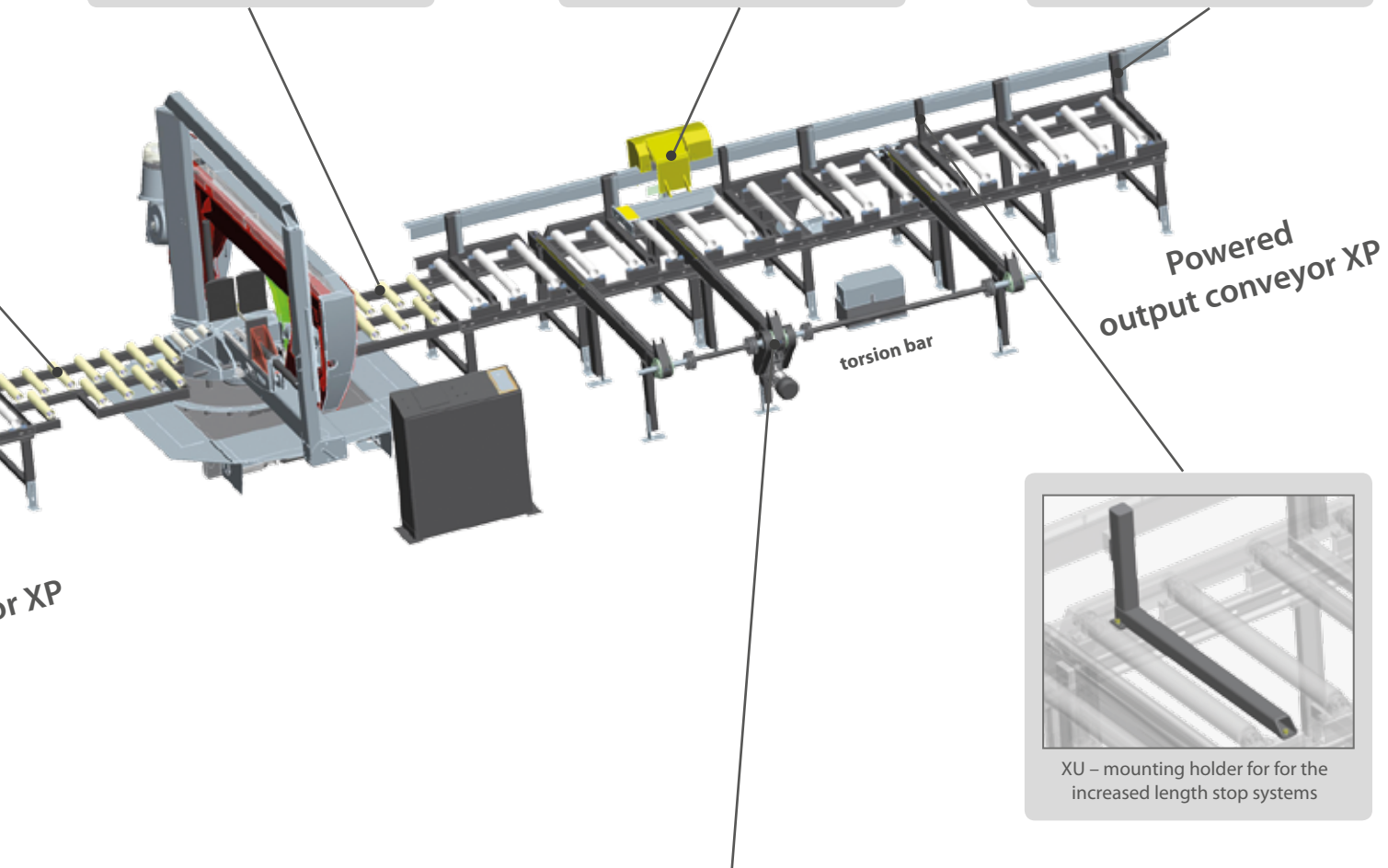

XU – mounting holder for for the increased length stop systems

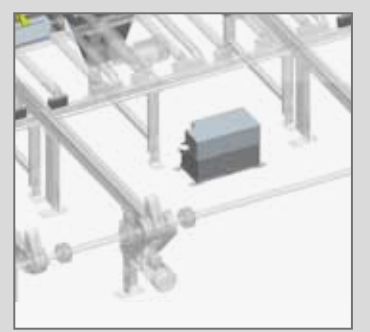
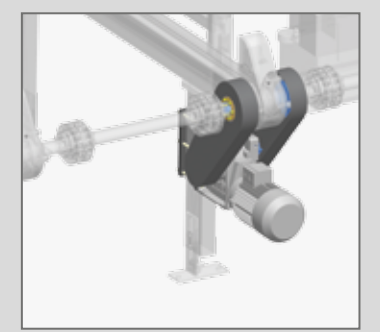
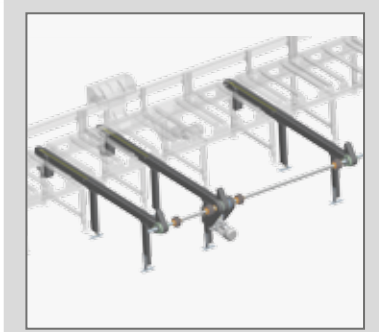

Cross feeder with front unloading, drive unit and own hydraulic lifting unit

# Quantity and power

Tato konfigurace s automatickou pásovou pilou, vstupní poháněnou nebo nepoháněnou tratí a stavitelnými vertikálními válečky je obzvláště vhodná pro řezání materiálu ve svazku.

- » **automatic band saw**
- » **powered or non-powered conveyor**
- » **adjustable Vertical rollers**

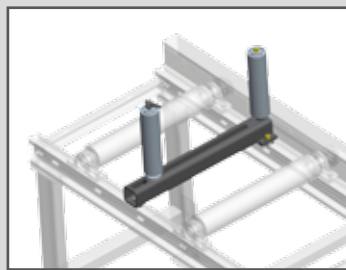

XVE – Adjustable Vertical roller

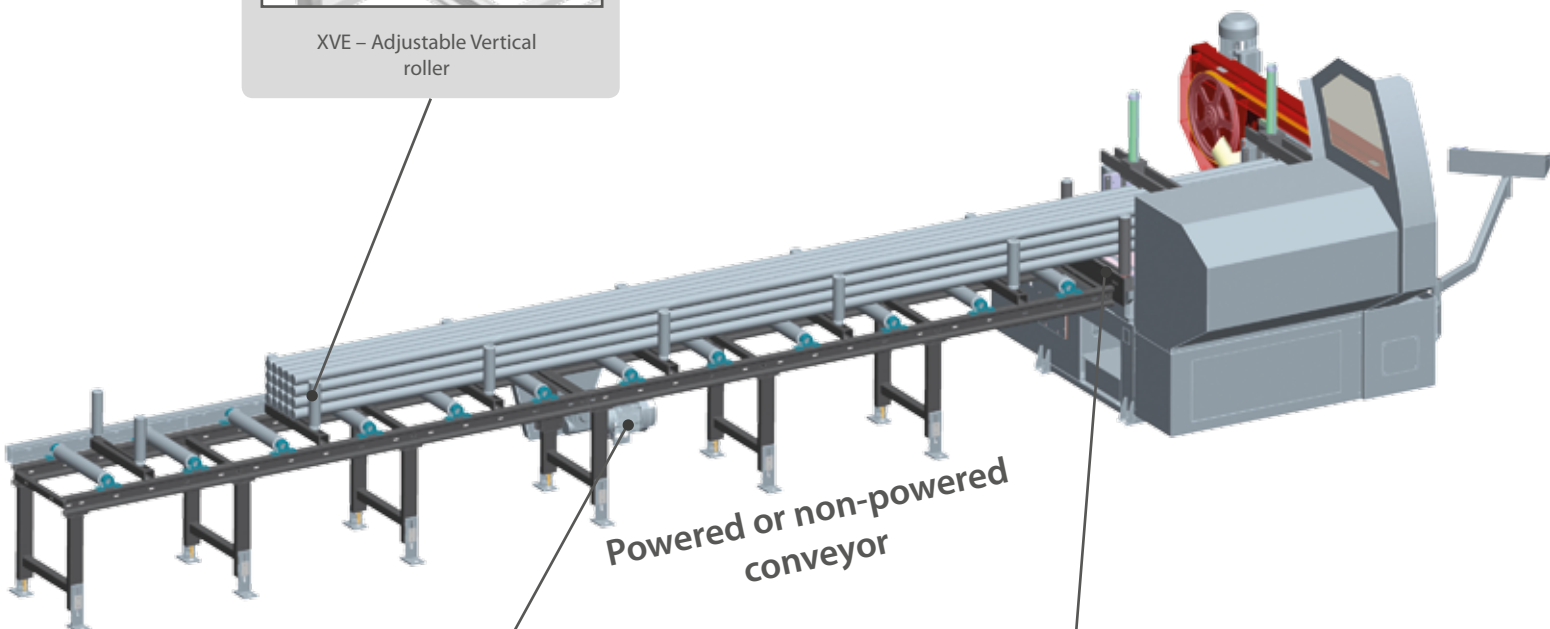

Powered or non-powered conveyor



Drive unit for conveyor XP



Connecting part