



# Workline





*Manual / Semiautomatic / Automatic*











#### Workline 410.280 DG / Technical parameters

					
	0°	280	410 x 280	410 x 280	280
Right	45°	280	310 x 150	260 x 280	270
Right	60°	210	205 x 100	175 x 280	190
Left	45°	280	330 x 100	290 x 280	280
Left	60°	220	225 x 100	170 x 280	210
Working mode	manual				
Smallest sawing diameter	ø 10 mm				
Shortest length of cut-off piece	60 mm				
Saw band speed	20 - 120 m/min				
Saw band dimensions	3 800 x 27 (25) x 0,9 mm				
Drive	2,2 kW, 3 x 400 V, 50 Hz				
Machine dimensions	Length - 1 070 mm / Width - 2 148 mm Height - 1 427 mm / Weight - 530 kg				

#### Workline 510.350 DG / Technical parameters

					
	0°	350	510 x 350	510 x 350	350
Right	45°	350	400 x 100	340 x 350	340
Right	60°	250	260 x 100	220 x 350	240
Left	45°	350	415 x 100	360 x 350	350
Left	60°	270	280 x 100	220 x 350	260
Working mode	manual				
Smallest sawing diameter	ø 10 mm				
Shortest length of cut-off piece	60 mm				
Saw band speed	20 - 120 m/min				
Saw band dimensions	4 780 x 34 (32) x 1,1 mm				
Drive	3 kW, 3 x 400 V, 50 Hz				
Machine dimensions	Length - 1 070 mm / Width - 2 500 mm Height - 1 450 mm / Weight - 685 kg				

# Workline manual

A gravity bandsaws, designed for double-sided mitre cuts and for cutting material up to 350 mm in diameter, provides high quality at an affordable price. The excellent cutting power results coming from these features: a hard-metal band precision guide, an arm joint laid in slide bearings, a 27 mm (34 mm) high saw band, and a synchronous running brush for chips disposal.

The work cycle starts with manual lifting of the arm to the required position and setting the angle for mitre cuts. Thanks to a large angle scale located within the operator's field of vision it is easy to set the required angle precisely. The material is inserted and clamped. An innovated vice allows the material to be clamped in several ways. The saw band speed is set on the ergonomic control panel located in the front of the machine. The basic equipment of the machine includes a frequency converter that allows the band's optimal speed to be set against the processed material within the 20-120 m/min range; this significantly increases both – the saw band lifetime and the machine productivity.

The machine is started by pressing the Start button, the arm downfeed speed is set with an overflow valve, and the cutting is performed.

When the cutting is completed, the arm remains in the lower position and the saw band turns off. The machine is intended for occasional cutting profile as well as full materials of smaller diameters in one-shift operation workshops.

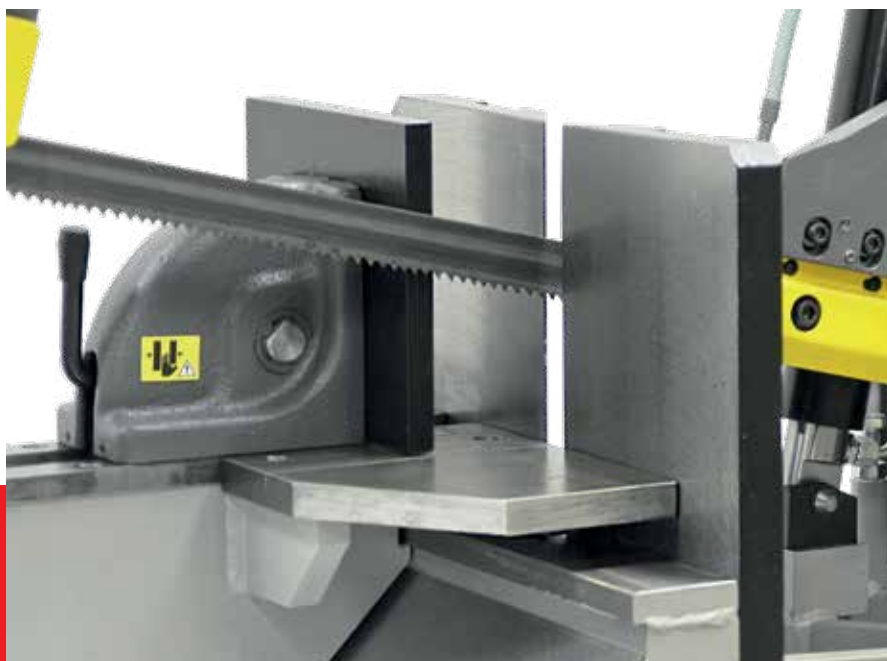

Hand-operated sawing machines of Workline series are equipped with a new kind of multifunction clamping system, offering in addition to the comfortable operation a continual full material feeding on face of the flexible clamping device.



The band-saw blade guides of the Workline series are equipped with accurate grinded guidances from the hard metal. The haul-back blocks in front of the guides are lightening the band-saw blade and increasing accuracy.



Freely adjustable control panel.



Distinctively designed scale for mitre cuts with well visible indicator is located directly on the front of the clamping device.



### Sample assembly

- Workline 410.280 DG
- Conveyor T440 with steel rollers
- Conveyor T440 with steel rollers
- Connection part T440 right
- Connection part T440 left
- TRA Manual material length-stop with digital display

### Saw band tension indicator

The saw band tension indicator provides permanent control of the band tension, even during the machine operation.



### System T / material conveyors

With the bearing capacity up to 600 kg/m and a wide range of accessories and connection parts for BOMAR band saws, the T system is an ideal partner for handling materials in your workshop. Thanks to the default lengths of 2 and 3 m, the roller tracks may be flexibly adjusted to any environment.



### Measuring stops System T

Next to the wide program for roller conveyors inclusive accessories the System T offers measuring stops in various designs. Their operation is from manual to CNC control.

#### TRA - manual length stop with digital counter



## Accessories, material conveyors

Workline DG bandsaw is supplied with unrivalled equipment. With intelligent optional equipment and accessories, the machine may be adapted precisely to individual requirements. With a wide range of accessories and connection pieces to BOMAR bandsaws, the handling "T" System is an ideal partner for handling material in your workshop.

For handling heavier materials the X series conveyors may be used. Thanks to their default length, roller tracks may be flexibly adjusted to any environment.



### Innovative accessories / selection



#### **Micro-spray-system**

For ideal cutting of pipes and profiles, the micro-spray unit applies a grease film on the teeth points and lateral sides of the saw band.



#### **Laser liner**

The laser unit copies the exact line in the saw band axis to the material. Laser Liner allows precise adjustment of the marked material.



#### **Tenzomat**

A precise measuring tool for the control of the saw band tension when a new band is installed.



#### **Manual bundle clamping device**

Device for clamping materials in layers and bundles with the use of an additional vertical clamping unit.



#### **Workspace lighting**

A lamp for lighting the workspace, adjustable and mounted on the flexible arm.



#### **Additional coolant inflow**

The additional coolant inflow is used for extra wide materials. If there is a need to get more coolant during the cut.



#### **Pistol for machine cleaning**





Tool for fast and easy cleaning of the machine from chips and burrs.







#### **Digital angle indicator**

Providing an accurate reading of the arm angles position on well readable digital display.



					
<b>Workline 410.280 DGH</b>	0°	280	410 x 280	410 x 280	280
Right	45°	280	310 x 150	260 x 280	270
Right	60°	210	205 x 100	175 x 280	190
Left	45°	280	330 x 100	290 x 280	280
Left	60°	220	225 x 100	170 x 280	210
Working mode	semiautomatic				
Smallest sawing diameter	ø 10 mm				
Length of cut-off piece	60 mm				
Saw band dimensions	3 800 x 27 (25) x 0,9 mm				
Drive	2,2 kW, 3 x 400 V, 50 Hz				
Saw band speed	20 - 120 m/min				
Machine dimensions	Length - 1 070 mm / Width - 2 148 mm Height - 1 428 mm / Weight - 570 kg				

					
<b>Workline 610.450 DGH</b>	0°	450	610 x 450	610 x 450	450
Right	45°	450	480 x 100	410 x 450	420
Right	60°	310	320 x 100	260 x 450	300
Left	45°	450	500 x 100	380 x 450	420
Left	60°	340	350 x 100	220 x 450	320
Working mode	semiautomatic				
Smallest sawing diameter	ø 10 mm				
Length of cut-off piece	60 mm				
Saw band dimensions	5 200 x 34 x 1,1 mm				
Drive	3 kW, 3 x 400 V, 50 Hz				
Saw band speed	20 - 120 m/min				
Machine dimensions	Length - 1 443 mm / Width - 2 781 mm Height - 1 564 mm / Weight - 800 kg				

					
<b>Workline 510.350 DGH</b>	0°	350	510 x 350	510 x 350	350
Right	45°	350	400 x 100	340 x 350	340
Right	60°	250	260 x 100	220 x 350	240
Left	45°	350	415 x 100	360 x 350	350
Left	60°	270	280 x 100	220 x 350	260
Working mode	semiautomatic				
Smallest sawing diameter	ø 10 mm				
Longest length of cut-off piece	60 mm				
Saw band speed	20 - 120 m/min				
Saw band dimensions	4 780 x 34 (32) x 1,1 mm				
Drive	3 kW, 3 x 400 V, 50 Hz				
Machine dimensions	Length - 1 070 mm / Width - 2 568 mm Height - 1 500 mm / Weight - 710 kg				



## Workline semiautomatic

This semiautomatic bandsaw, designed for double-sided mitre cuts and for cutting material up to 450 mm in diameter, provides high quality at an affordable price. The excellent cutting power results from these features: a hardmetal band precision guide, an arm joint laid in slide bearings, solid saw band, and a synchronous running brush for chips disposal. Material clamping and arm downfeed are controlled hydraulically, material feed is controlled manually.

The whole work cycle is completed at the press of the Start button: the material is clamped, the saw band starts up, cutting is carried out, the arm is raised to the default position, and the vice is opened. After switching the machine to the manual mode, all functions may be controlled separately. Thanks to a large angle scale located within the operator's field of vision it is easy to set the required angle precisely. The saw band speed is set on the ergonomic control panel located in the front of the machine. The basic equipment of the machine includes a frequency converter that allows the band's optimal speed to be set against the processed material within the 20-120 m/min range; this significantly increases both the saw band lifetime and the machine productivity. Standard equipment of Workline semiautomatic machines includes automatic downfeed pressure regulation dependent on the resistance of the processed material.



The moveable clamping device for mitre cuts – with double laying – can be moved easily.

The ADFR system regulates automatically and in real time the coordination of the cutting pressure and downfeeding.



Freely adjustable control panel.



The saw band guiding is equipped with a hardmetal precision guide. Guiding rolls relieve the saw band and increase the cutting precision.

### Equipment as an argument

- Continuous both-sided mitre cuts up to 60°
- A large, easy-to-read angular scale on the front side of the machine by the mitre cuts clamping lever
- A full-stroke hydraulic vice with a tightening system
- An easily movable clamping vice for mitre cuts
- A large hydraulic unit
- Brushes for removing chips, synchronous with the band speed
- A simple, easy-to-read control panel
- Electronic control of the band tensioning and rupture

Sho



### Sample assembly

- Workline 410.280 DGH
- Conveyor T440 with steel rollers
- Conveyor T440 with steel rollers
- Connection part T440 right
- Connection part T440 left
- TRA Manual material length-stop with digital display

### Saw band tension indicator

The saw band tension indicator provides permanent control of the band tension, even during the machine operation.



### System T / material conveyors

With the bearing capacity up to 600 kg/m and a wide range of accessories and connection parts for BOMAR band saws, the T system is an ideal partner for handling materials in your workshop. Thanks to the default lengths of 2 and 3 m, the roller tracks may be flexibly adjusted to any environment.

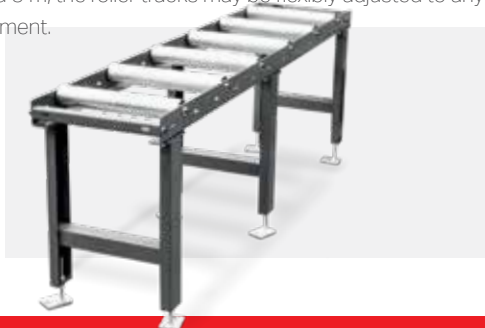

### System X / material conveyors feeding heavy material

Highly flexible handling solutions for heavy feed. Thanks to the unique profile system can be the System X roller conveyors individually adjusted to customer wishes any time, the load-bearing increases or if you like the roller distances changes. The accessories and bodywork parts high volume program integrates the System X spectrum.



## Accessories, material conveyors

Workline DGH bandsaw is supplied with unrivalled equipment. With intelligent optional equipment and accessories, the machine may be adapted precisely to individual requirements. With a wide range of accessories and connection pieces to BOMAR bandsaws, the handling "T" System is an ideal partner for handling material in your workshop.

For handling heavier materials the X series conveyors may be used. Thanks to their default length, roller tracks may be flexibly adjusted to any environment.



### Innovative accessories / selection



#### **Micro-spray-system**

For ideal cutting of pipes and profiles, the micro-spray unit applies a grease film on the teeth points and lateral sides of the saw band.



#### **Laser liner**

The laser unit copies the exact line in the saw band axis to the material. Laser Liner allows precise adjustment of the marked material.



#### **Tenzomat**

A precise measuring tool for the control of the saw band tension when a new band is installed.



#### **Hydraulic bundle clamping device**

Device for clamping materials in layers and bundles with the use of an additional vertical clamping unit.



#### **Workspace lighting**

A lamp for lighting the workspace, adjustable and mounted on the flexible arm.



#### **Additional coolant inflow**

The additional coolant inflow is used for extra wide materials. If there is a need to get more coolant during the cut.



#### **Digital angle indicator**

Providing an accurate reading of the arm angles position on well readable digital display.



#### **Vice pressure regulation**





The pressure regulation of both cylinders is centrally preset, firstly to be avoided of the deformations by thin-walled pipes and profiles.



## Equipment as an argument

- Feeding length 600 mm at a simple stroke, total feeding up to 9,999 mm
- New main vice fitted with a tightening system for full fitting of workpieces and the best material clamping
- Full-stroke cylinder for the feeding and main vices
- Continuous regulation of the band speed with a frequency convertor within the 20-120 m/min range
- Automatic pressure regulation during cutting – according to the material shape and quality
- Brushes for removing swarf, synchronous with the band speed
- Control system with a large display and foil keyboard
- Movable control panel with all control elements located on the front side of the machine

## Workline 510.350 GANC / Technical parameters

					
	0°	350	510 x 350	510 x 350	350
Right	45°	350	400 x 100	340 x 350	340
Right	60°	250	260 x 100	220 x 350	240
Working mode	automatic				
Smallest sawing diameter	ø 10 mm				
Shortest length of cut-off piece	60 mm				
Saw band speed	20 - 120 m/min				
Saw band dimensions	4 780 x 34 (32) x 1,1 mm				
Drive	3 kW, 3 x 400 V, 50 Hz				
Machine dimensions	Length - 2 880 mm / Width - 2 441 mm Height - 1 538 mm / Weight - 950 kg				

## Workline automatic

This automatic bandsaw is a maximally flexible machine suitable for small-quantity production. It is designed for performing single-sided mitre cuts up to 60° in the semiautomatic mode, and for cutting material up to 350 mm in diameter at 0° in the automatic mode. It provides high quality at an affordable price. The excellent cutting power results from these features: a hardmetal band precision guide, an arm joint laid in slide bearings, a 34 mm high saw band, and a synchronous running brush for chips disposal. Material clamping and arm downfeed are performed by hydraulic full-stroke vices. Material feed is controlled hydraulically, too.

The whole cutting cycle is controlled with a simple dialogue system on an LCD panel. After switching the machine to the semiautomatic mode, all functions are controlled with a membrane keyboard. Thanks to a large angle scale located within the operator's field of vision it is easy to set the required angle precisely. The saw band speed is set on the ergonomic control panel connected to the machine with flexible hoses. The basic equipment of the machine includes a frequency converter that allows the band's optimal speed to be set against the processed material within the 20-120 m/min range; this significantly increases both the saw band lifetime and the machine productivity. Standard equipment of Workline automatic machines includes automatic downfeed pressure regulation dependent on the resistance of the processed material.



The main vices of Workline automatic machines are equipped with an innovated clamping system – offering comfortable operation with a full-stroke cylinder and stable support of material in the clamping vice.



Freely adjustable control panel.



The automatic cutting pressure regulation automatically adapts the cutting feed and pressure to the material. The result is higher cutting output and longer service life.



Workline automatic machines are enclosed with a safety grid. When performing mitre cuts, the rear cover shall be open, preventing the performance of the automatic cycle.



**Saw band tension indicator**

The saw band tension indicator provides permanent control of the band tension, even during the machine operation.



**Digital angle indicator**

Providing an accurate reading of the arm angles position on well readable digital display.

**Sample assembly**

- Workline 410.280 GANC
- Conveyor T440 with steel rollers
- Conveyor T440 with steel rollers
- Connection part T440 right
- Connection part T440 left
- Safety system SECURFLEX

**System T / material conveyors**

With the bearing capacity up to 600 kg/m and a wide range of accessories and connection parts for BOMAR band saws, the T system is an ideal partner for handling materials in your workshop. Thanks to the default lengths of 2 and 3 m, the roller tracks may be easily adjusted to any environment.



## Accessories, material conveyors

Workline GANC bandsaw is supplied with unrivalled equipment. With intelligent optional equipment and accessories, the machine may be adapted precisely to individual requirements. With a wide range of accessories and connection pieces to BOMAR bandsaws, the handling "T" System is an ideal partner for handling material in your workshop.

For handling heavier materials the X series conveyors may be used. Thanks to their default length, roller tracks may be flexibly adjusted to any environment.



### Innovative accessories / selection



#### **Micro-spray-system**

For ideal cutting of pipes and profiles, the micro-spray unit applies a grease film on the teeth points and lateral sides of the saw band.



#### **Laser liner**

The laser unit copies the exact line in the saw band axis to the material. Laser Liner allows precise adjustment of the marked material.



#### **Tenzomat**

A precise measuring tool for the control of the saw band tension when a new band is installed.



#### **Hydraulic bundle clamping device**

Device for clamping materials in layers and bundles with the use of an additional vertical clamping unit.



#### **Workspace lighting**

A lamp for lighting the workspace, adjustable and mounted on the flexible arm.



#### **Additional coolant inflow**

The additional coolant inflow is used for extra wide materials. If there is a need to get more coolant during the cut.



#### **Pistol for machine cleaning**

Tool for fast and easy cleaning of the machine from chips and burrs.



#### **Vice pressure regulation**

The pressure regulation of both cylinders is centrally preset, firstly to be avoided of the deformations by thin-walled pipes and profiles.



BOMAR, spol. s r.o.  
Těžební 1236/1  
627 00, Brno  
Česká Republika

Tel. + 420 533 426 100  
info@bomar.cz

**[www.bomar-saws.com](http://www.bomar-saws.com)**